

Motorenfabrik Hatz GmbH & Co. KG

Ernst-Hatz-Str. 16
94099 Ruhstorf a.d. Rott
Deutschland
Tel. +49 8531 319-0
Fax +49 8531 319-418
marketing@hatz-diesel.de
www.hatz-diesel.com

CREATING POWER SOLUTIONS.

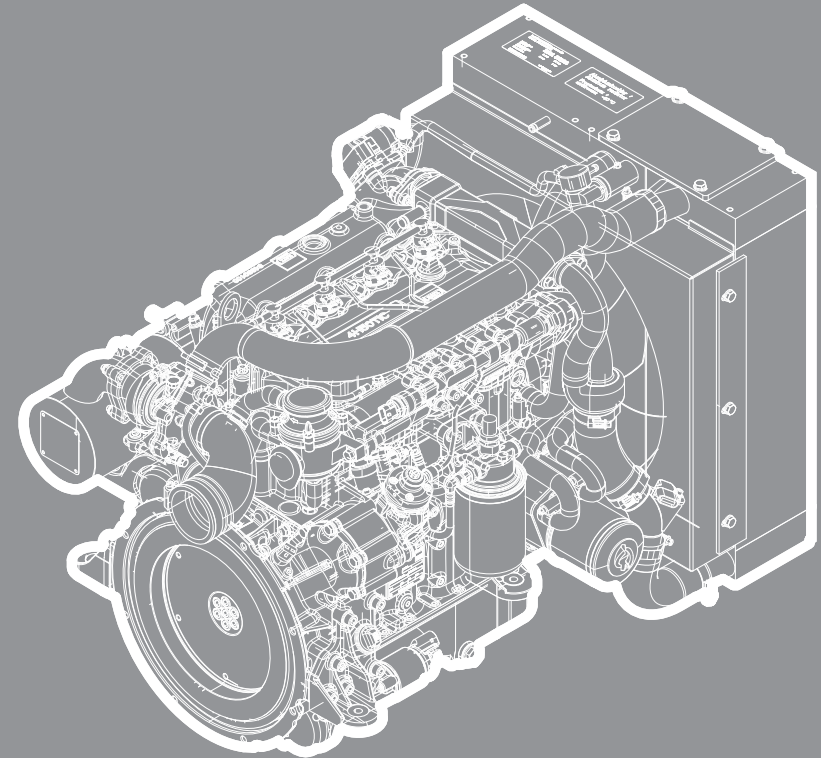

4H50TIC

Original - spare parts
Original - Ersatzteile
Pièces de rechange d'origine
Repuestos originales
Pezzi di ricambio originali

Hatz Service

0000 437 001 00
34 - 03.2015 - 0.001

Printed in Germany

We reserve the right to make all
changes that serve technical
development.



CREATING POWER SOLUTIONS.

www.HATZ-DIESEL.com



Original - spare parts
 Original - Ersatzteile
 Pièces de rechange d'origine
 Repuestos originales
 Pezzi di ricambio originali

① TYPE / SPEC. / FDT
② SERIAL NO.
③ MIN ⁻¹

Nearest HATZ service station:

Nächste HATZ-Servicestelle:

Station-service HATZ la plus proche:

Servicio HATZ más cercano:

Più vicino centro di servizio HATZ:

www.hatz-diesel.com

EMISSION CONTROL INFORMATION	
MOTORENFABRIK HATZ KG · D-94099 RÜHSTORF	
ENG.FAM.	MADE IN GERMANY
mm ³ /h	
TYPE / SPEC. / FDT	
①	
SERIAL NO.	
②	Liter / PV
MIN ⁻¹	NH / KW
③	BUILD DATE
This engine conforms to LM U.S. EPA regulations large nominal compression-ignition engines and MY California regulation for off-road compression-ignition engines. Refer to Owner's manual for maintenance specifications and adjustments.	
EC-TYPE NO.	
CONSTANT-SPEED ONLY VARIABLE SPEED	

Spare parts list no./ Ersatzteilliste Nr./ Liste des pièces de rechange no./ Lista de repuestos No./ Lista ricambi n.

4 H 50 TIC.10 EPA TIER IV □ (136 10)



Example: / Beispiel: / Exemple: / Ejemplo: / Esempio: **136 10 15 123456**

Engine type No. | Engine series | Prod. year | Consecutively number

Always have service work performed by qualified specialists. To this effect, we recommend that you consult one of the 500 **HATZ service stations**. There, your engine is repaired by staff who constantly undergo training and who use both **original HATZ spare parts** and **HATZ tools**. The installation of inappropriate spare parts may cause problems. We cannot accept any liability for damage or consequential damage resulting therefrom. Thus, we recommend that you use **original HATZ spare parts**. These parts are manufactured following the strict **HATZ** specifications and ensure, thanks to their perfect fit and function, maximum operating reliability.

Lassen Sie Service-Arbeiten immer von qualifiziertem Fachpersonal durchführen. Wir empfehlen Ihnen hierfür eine von über 500 **HATZ-Servicestationen**. Dort wird Ihr Motor von laufend geschultem Personal, mit **Original HATZ-Ersatzteilen** und mit **HATZ-Werkzeug** instandgesetzt. Der Einbau von ungeeigneten Ersatzteilen kann zu Problemen führen. Für Schäden oder Folgeschäden, die daraus entstehen, können wir keine Haftung übernehmen. Wir empfehlen deshalb die Verwendung von **Original HATZ-Ersatzteilen**. Diese Teile sind nach den strengen **HATZ**-Spezifikationen gefertigt und sorgen durch ihre perfekte Passform und Funktion für höchste Betriebssicherheit.

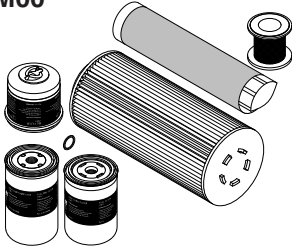
Toujours faire effectuer les travaux de service après-vente par un personnel qualifié. Nous vous conseillons de contacter un des 500 **ateliers agréés HATZ**. Votre moteur y sera réparé par un personnel formé régulièrement et utilisant des **pièces de rechange d'origine HATZ** et l'**outillage HATZ**. Le montage de pièces de rechange adaptables peut entraîner des problèmes. Nous n'assumons aucune responsabilité pour des dommages directs ou indirects qui en découlent. Pour cette raison, nous vous recommandons l'utilisation des **pièces de rechange d'origine HATZ**. Ces pièces sont usinées selon les spécifications sévères **HATZ** et grâce à l'adaptation et le fonctionnement parfaits elles garantissent un maximum de sécurité de fonctionnement.

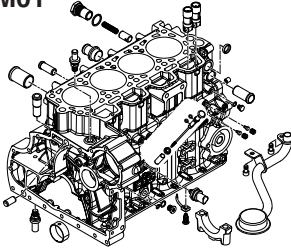
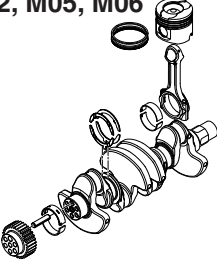
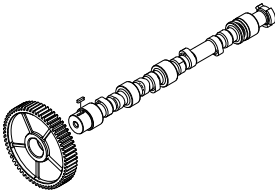
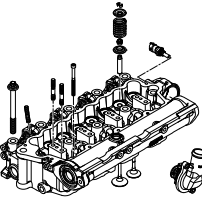
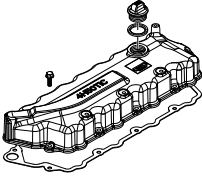
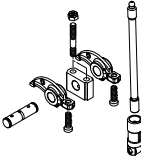
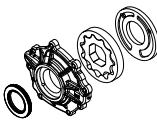
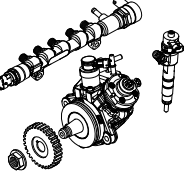
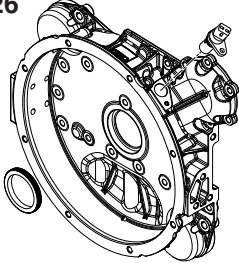
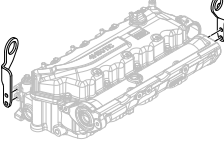
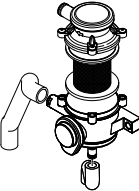
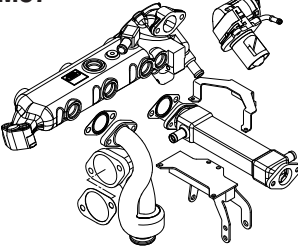
M00 	M34 	M01 
M02, M05, M06 	M04 	M07 
M08 	M09 	M10 
M14 	M26 	M30 
M31 	M37 	

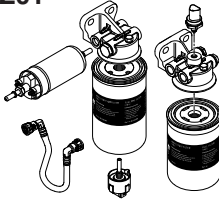
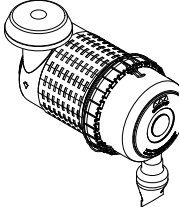
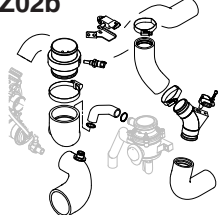
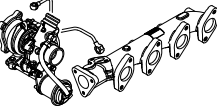
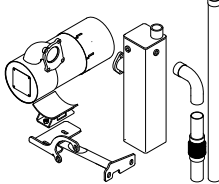
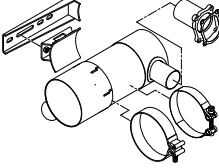
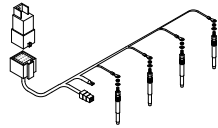
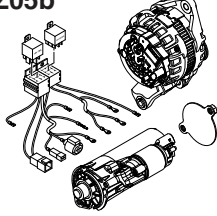
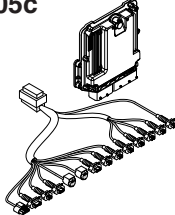
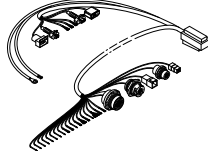
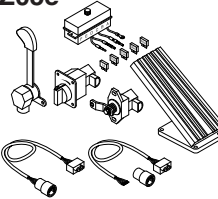
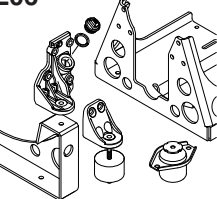
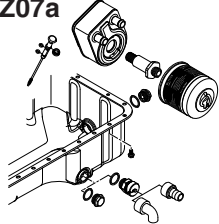
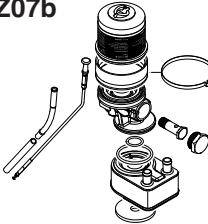
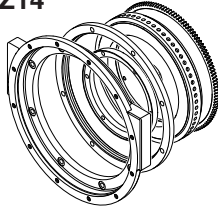
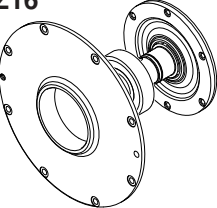
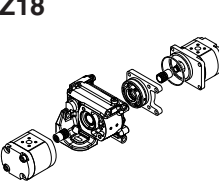
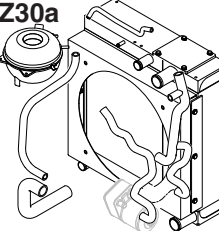
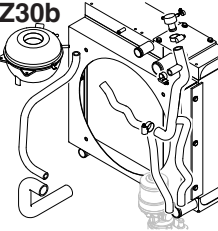
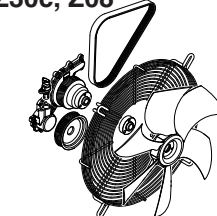
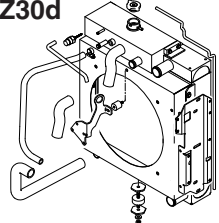
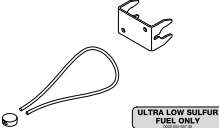
Z01 	Z02a 	Z02b 	Z03a 
Z03b 	Z03c 	Z05a 	Z05b 
Z05c 	Z05d 	Z05e 	Z06 
Z07a 	Z07b 	Z14 	Z16 
Z18 	Z30a 	Z30b 	Z30c, Z08 
Z30d 	Z90  <p>ULTRA LOW SULFUR FUEL ONLY</p>		

MOO

Spare parts kits
Ersatzteilsätze
Jeux de pièces de rechange
Juegos de piezas de recambios
Serie guarnizioni

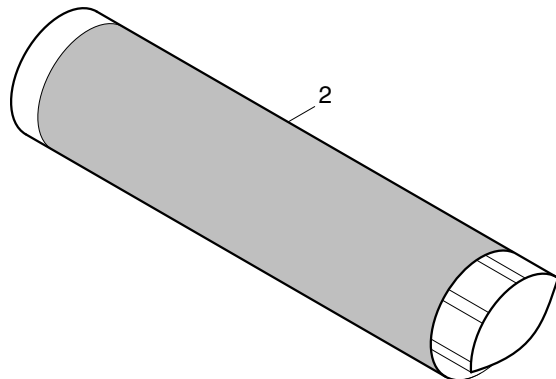
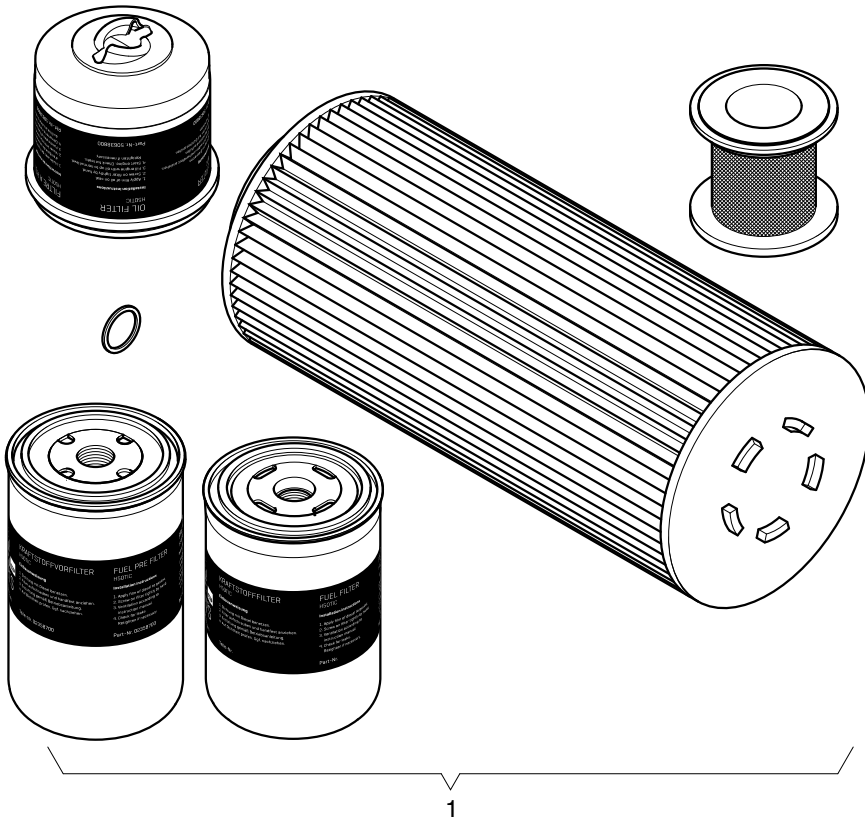
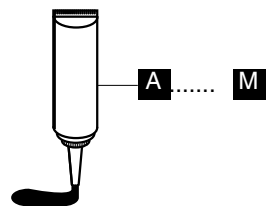

Fig.- No.	HATZ Ident-No.	Qty. Stück	W d / D	Notes Bemerkungen
		4H50TIC		
1	0000 024 040 00	1		500h / 2 years
2	0000 506 383 00	1		2 years

M34

Accessories
Zubehör
Accessoires
Accessorios
Kit accessori



1 THIS ENGINE IS SOLELY FOR EXPORT AND IS THEREFORE EXEMPT UNDER 40 CFR 1068.230 FROM U.S. EMISSION STANDARDS AND RELATED REQUIREMENTS 0000 043 231 00

HATZ
Motorenfabrik Hatz GmbH & Co. KG

Fig.- No.	HATZ Ident-No.	Qty. Stück	W d / D	Notes Bemerkungen
4H50TIC				
1	0000 043 231 00	1		

Sealing- and bonding adhesives Dicht- und Klebstoffe Etanchéifiant et Colle			Materias para empaquetar y pegar Adesivi e collanti	
A =	0000 502 230 01	Loctite Activator N	500 ml	as specified in the individual tables siehe Hinweis auf den einzelnen Bildtafeln suivant les remarques sur les tableau correspondant según las indicaciones de las tablas correspondientes seguire le indicazioni sul quadro corrispondente
B =	0000 502 231 01	Loctite 574	50 ml	
C =	0000 502 232 00	Loctite 601	50 ml	
D =	0000 700 189 18	Loctite 243	50 ml	
E =	0000 502 234 00	Loctite 648	10 ml	
F =	0000 502 238 00	Technicoll 8058	0,75 kg	
	+ 0000 502 239 00	Technicoll 8367	0,75 kg	
G =	0000 502 565 01	Loctite IS 407	20 g	
H =	0000 700 189 44	Silicon	310 ml	
J =	0000 502 830 04	Hochtemp. Paste	100 ml	
K =	0000 503 426 01	Hochtemp. Fett	400 g	
L =	0000 502 566 00	Silicon sealer	100 g	
M =	0000 504 851 00	Schleifpaste	80 g	

M01

Crankcase
Kurbelgehäuse
Carter moteur
Caja cigueñal
Basamento motore

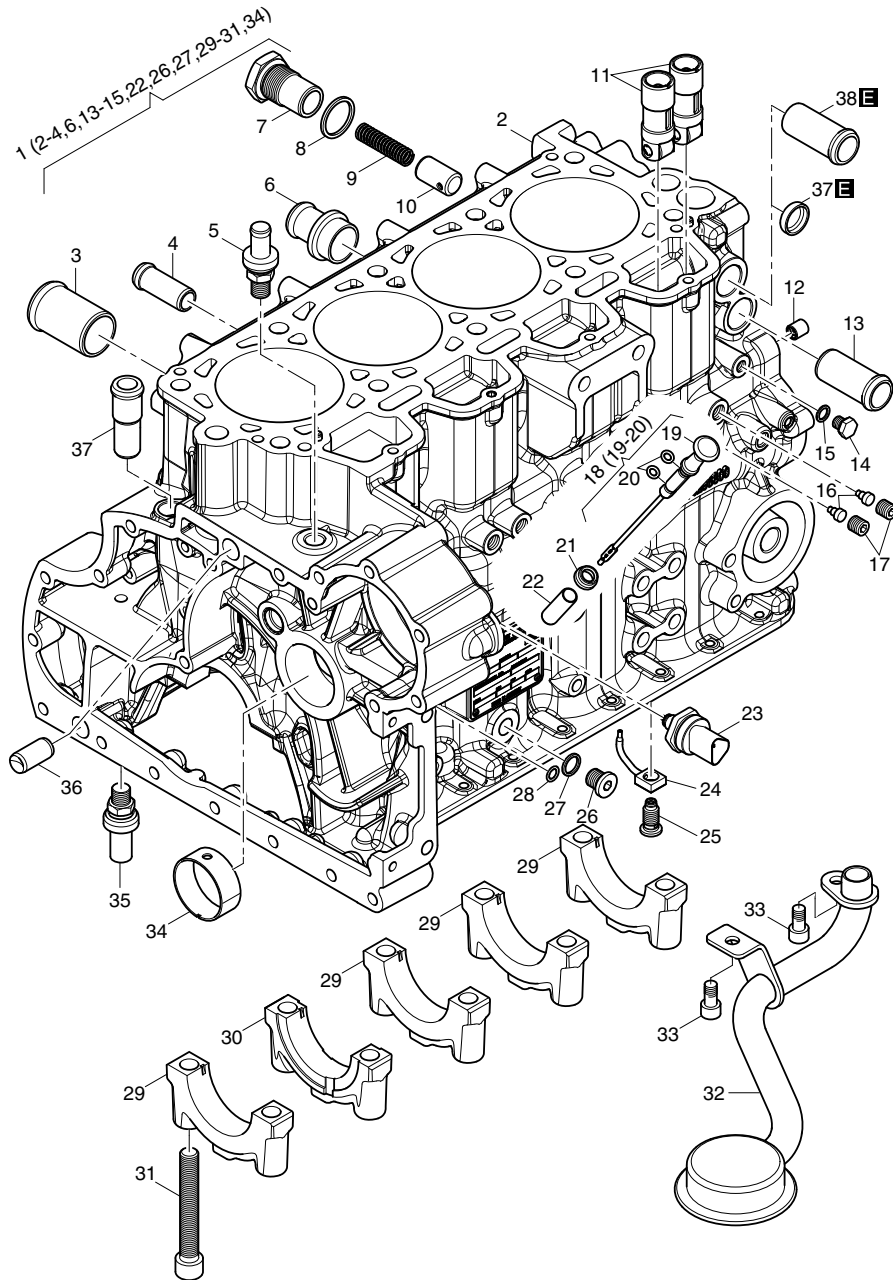

Fig.- No.	HATZ Ident-No.	Qty. Stück	W d / D	Notes Bemerkungen
4H50TIC				
1	0000 020 316 10	1		
2	-----	-		
3	-----	-		
4	-----	-		
5	0000 042 971 00	1		
6	-----	-		
7	0000 042 959 00	1		
8	0000 502 864 00	1		A 24 x 29 DIN 7603-Cu
9	0000 036 399 00	1		
10	0000 036 398 00	1		
11	0000 020 320 00	8		
12	0000 042 953 00	1		
13	-----	-		
14	0000 501 379 00	1		M 8 x 1 DIN 7604
15	0000 500 009 00	1		A 8 x 11,5 DIN 7603-Cu
16	0000 042 954 00	8		
17	0000 506 274 00	8		M 10 X 10 A3B DIN 913 ST
18	0000 020 335 00	1		
19	-----	-		
20	0000 400 220 00	2		5 x 2
21	0000 040 845 00	1		
22	0000 042 991 00	1		
23	0000 506 337 00	1		
24	0000 042 975 00	4		
25	0000 506 328 00	4		
26	0000 504 592 00	1		M 12 x 1,5 DIN 908 - St A3C
27	0000 500 011 00	1		A 12 x 15,5 DIN 7603-Cu
28	0000 505 136 00	1		7 x 2
29	0000 042 969 00	4		
30	0000 042 970 00	1		
31	0000 506 275 00	10		M 12 X 85 DIN 912 - 10.9
32	0000 020 332 00	1		
33	0000 500 516 00	2		M 8 x 16 DIN 912 - 8.8
34	0000 042 998 00	2		
35	0000 043 109 00	1		
36	0000 506 325 00	2		14 M 6 X 28 DIN 6325
37	0000 503 458 00	0... 1		22 DIN 443
38	0000 042 976 00	0... 1		Ø22

M02, M05, M06

Crankshaft, piston, conrod, cylinder
 Kurbelwelle, Kolben, Pleuel, Zylinder
 Vilebrequin, piston, bielle, cylindre
 Cigüeñal, Embolo, biela, cilindro
 Albero a gomito , pistone, biella, cilindro

Fig.- No.	HATZ Ident-No.	Qty. Stück	W d / D	Notes Bemerkungen
--------------	-------------------	---------------	------------	----------------------

4H50TIC

1	0000 042 985 00	1		
2	0000 506 308 00	1		
3	0000 023 991 00	5		
4	0000 023 992 00	2		
5	0000 043 254 00	1		
6	0000 023 993 00	4		
7	0000 043 021 00	8		
8	-----	-		
9	0000 020 358 01	4		
10	0000 506 330 00	8		
11	-----	-		
12	-----	-		
13	-----	-		
14	0000 020 353 00	4		
14	0000 020 354 00	4		

+0,5mm

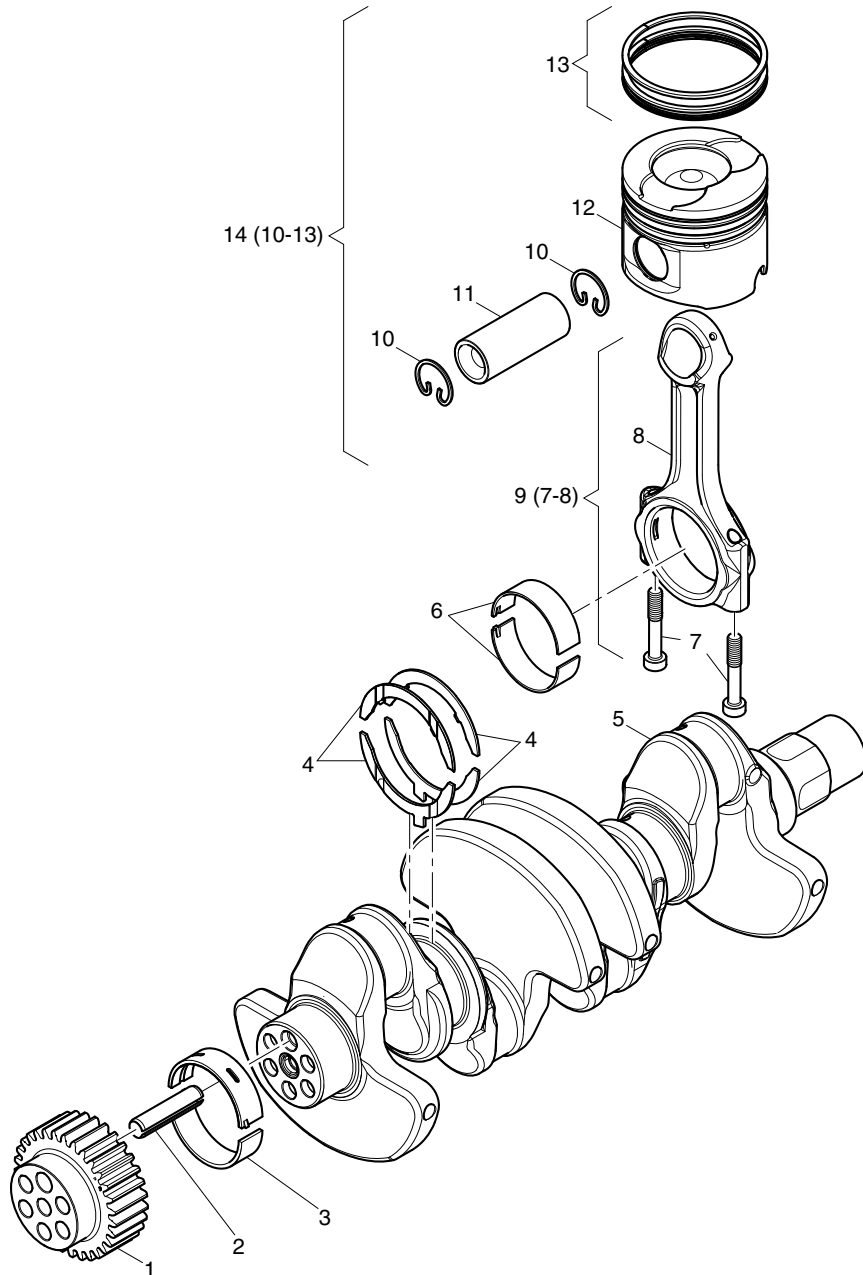

M04

Camshaft
Nockenwelle
Arbre à cames
Arbol de levas
Albero a camme

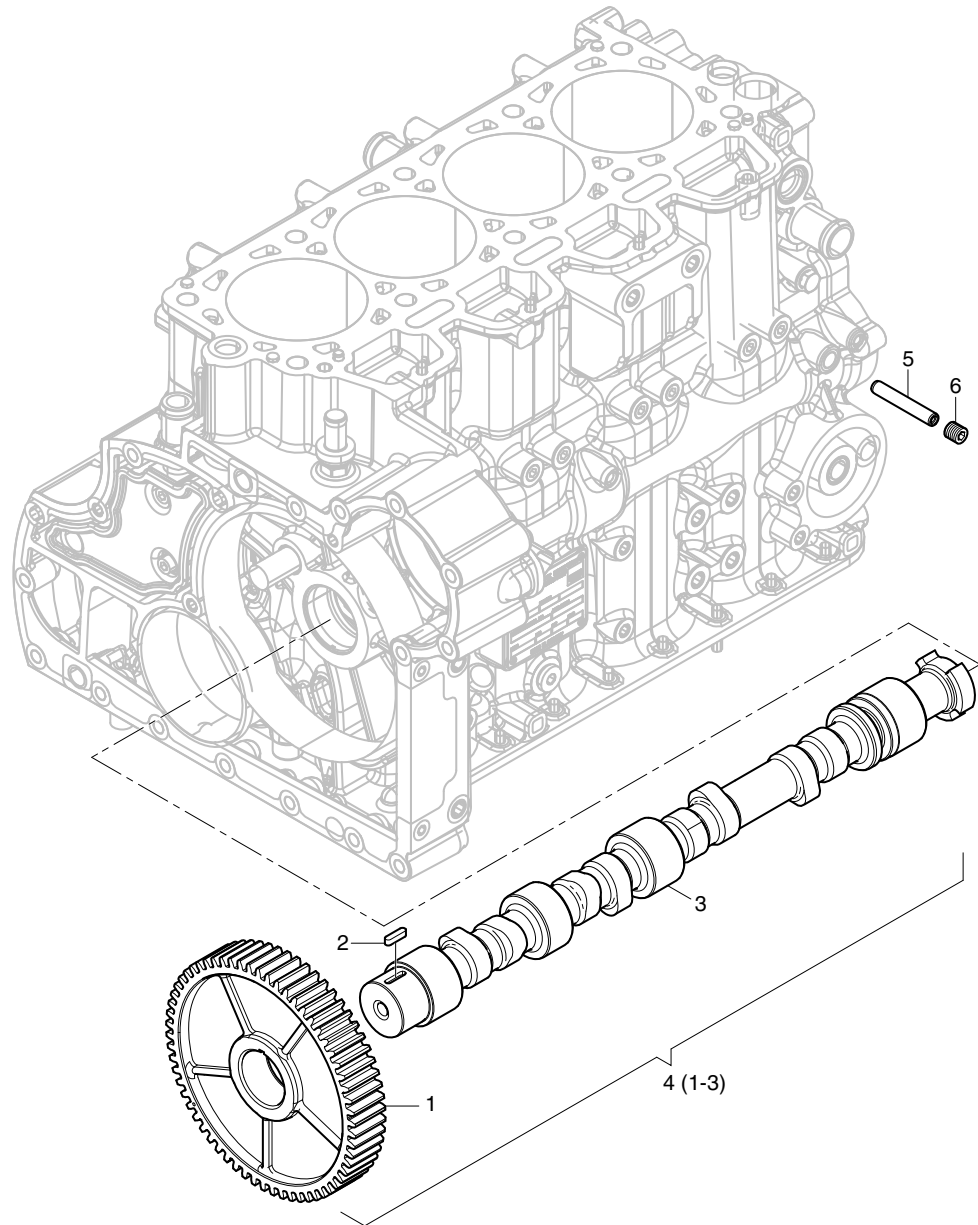

Fig.- No.	HATZ Ident-No.	Qty. Stück	W d / D	Notes Bemerkungen
4H50TIC				
1	0000 042 986 00	1		
2	0000 506 366 00	1		
3	-----	-		
4	0000 020 334 01	1		
5	0000 506 297 00	1		
6	0000 506 274 00	1		M 10 X 10 A3B DIN 913 ST

M07

Cylinder head
Zylinderkopf
Culasse
Culata
Testa

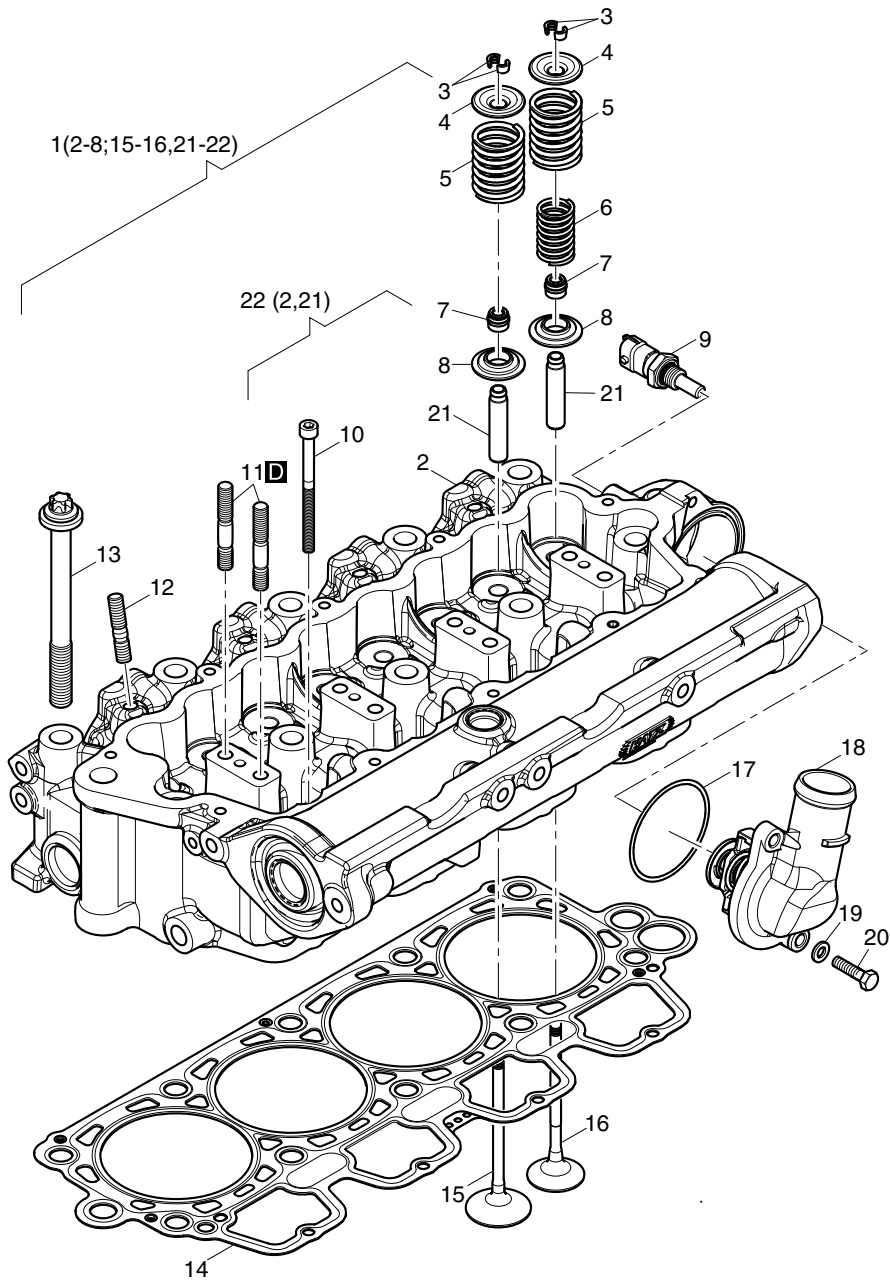

Fig.- No.	HATZ Ident-No.	Qty. Stück	W d / D	Notes Bemerkungen
4H50TIC				
1	0000 020 311 02	1		
2	-----	-		
3	0000 504 257 00	16		
4	0000 042 946 00	4		
5	0000 042 944 00	8		
6	0000 042 945 00	8		
7	0000 506 310 00	8		
8	0000 042 947 00	8		
9	0000 506 336 00	1		
10	0000 504 443 00	4		M 6 x 80 DIN 912-8.8A3C
11	0000 502 792 00	8		M 8 x 40 DIN 835-8.8 A3C
12	0000 502 319 00	4		M 8 x 25 DIN 835-8.8 A3C
13	0000 042 948 00	10		M12 x 130
14	0000 042 949 00	0... 1		0,4mm
14	0000 042 950 00	0... 1		0,5mm
14	0000 042 951 00	0... 1		0,6mm
15	0000 042 941 00	4		
16	0000 042 942 00	4		
17	0000 506 284 00	1		58 x 2
18	0000 023 556 00	1		
19	0000 501 445 00	2		6,4 DIN 125-St A3C
20	0000 500 921 00	2		M 6 x 25 DIN 933-8.8 A3C
21	-----	-		
22	0000 020 312 03	1		

M08

Cylinder head cover
 Zylinderkopfdeckel
 Couvercle de culasse
 Tapa culata
 Coperchio bilancieri

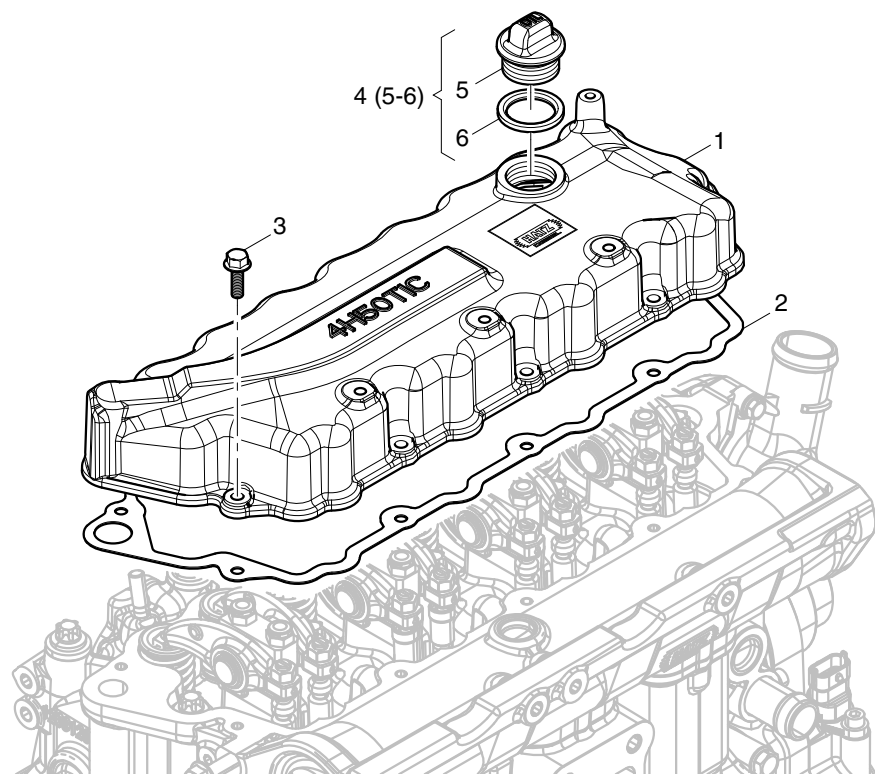

Fig.- No.	HATZ Ident-No.	Qty. Stück	W d / D	Notes Bemerkungen
4H50TIC				
1	0000 020 324 01	1		
2	0000 043 039 00	1		
3	0000 506 326 00	9		
4	0000 016 131 00	1		
5	-----	-		
6	0000 041 250 00	1		26 x 35 x3

Pushrod + Rocker bracket
 Stosstange und Kipphebelbock
 Tige de culbuteur + Support
 Varilla de balancin + Soporte
 Pushrod + Rocker bracket

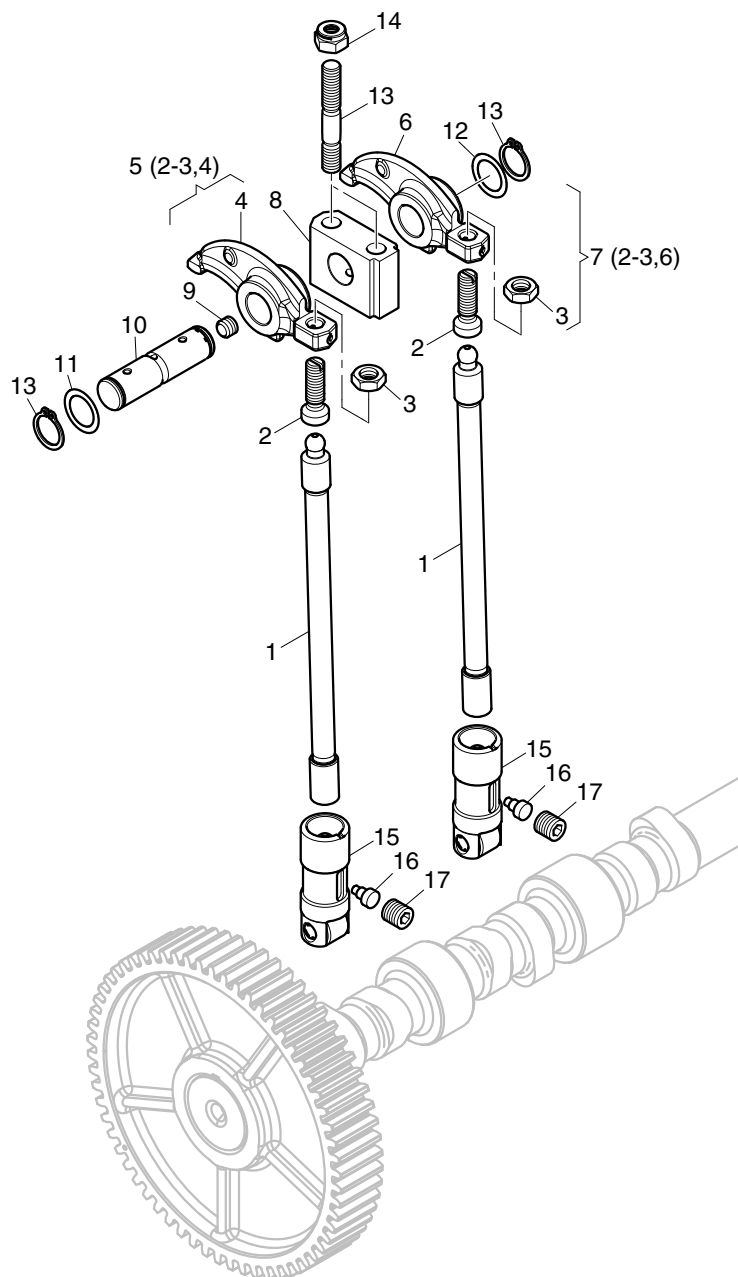

Fig.- No.	HATZ Ident-No.	Qty. Stück	W d / D	Notes Bemerkungen
4H50TIC				
1	0000 043 068 00	8		
2	0000 043 070 00	8		
3	0000 031 731 00	8		
4	-----	-		
5	0000 020 387 00	4		
6	-----	-		
7	0000 020 388 00	4		
8	0000 043 027 00	4		
9	0000 502 260 00	4		M 8 x 6 DIN 913-45H TU.FLEC
10	0000 043 069 00	4		
11	0000 503 159 00	0..16		15 x 21 x 0,2 DIN 988
12	0000 503 160 00	0..16		15 x 21 x 0,3 DIN 988
13	0000 500 198 00	8		A15 x 1 DIN 471
14	0000 400 284 00	8		VM 8 DIN 980-8 C3A
15	0000 020 320 00	8		
16	0000 042 954 00	8		
17	0000 506 274 00	8		M 10 X 10 A3B DIN 913 ST

M10

Oil pump
 Ölpumpe
 Pompe a huile
 Bomba de aceite
 Pompa olio

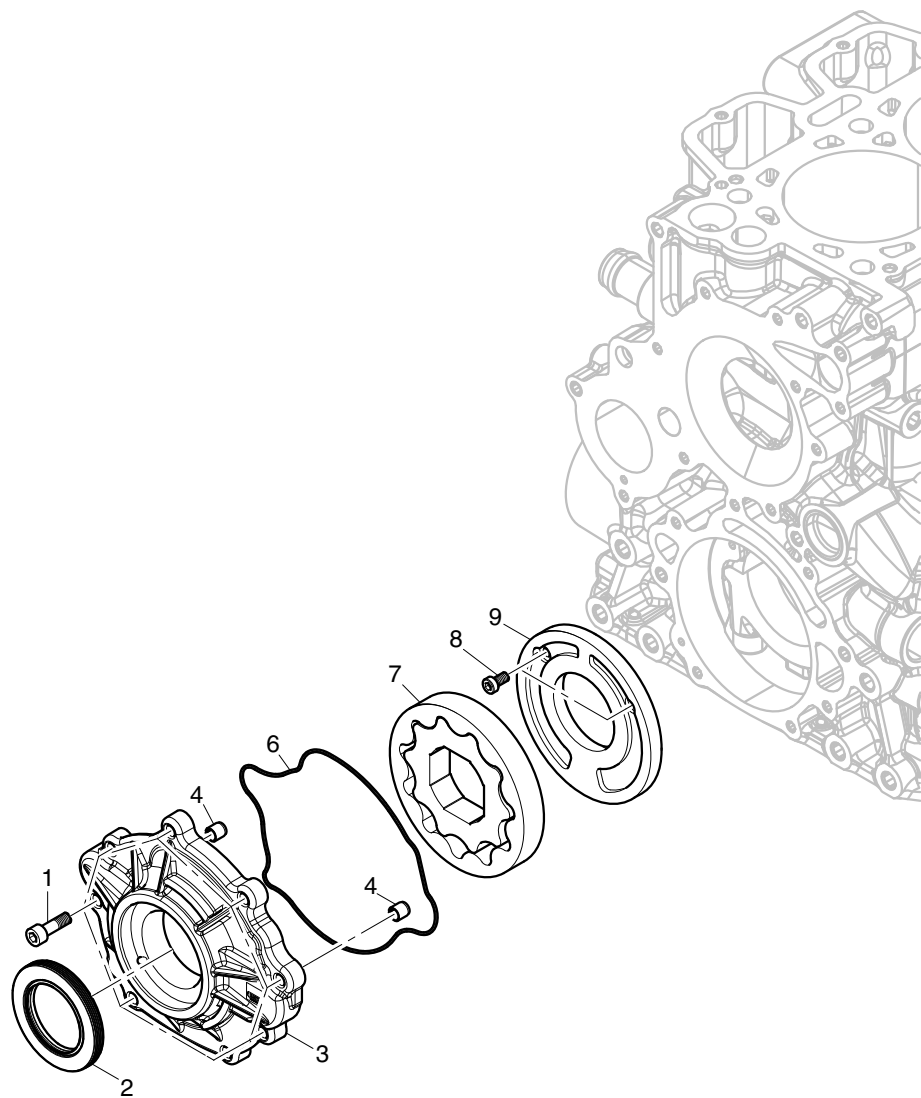

Fig.- No.	HATZ Ident-No.	Qty. Stück	W d / D	Notes Bemerkungen
4H50TIC				
1	0000 501 706 00	8		M 6 x 20 DIN 912-8.8A3C
2	0000 505 108 01	1		40 x 62 x 7
3	0000 042 961 00	1		
4	0000 501 400 00	2		8 x 8 DIN 7346 55 Si 7
6	0000 043 001 00	1		
7	0000 042 958 00	1		
8	0000 501 126 00	2		M 5 x 10 DIN 6912-8.8 A3C
9	0000 042 962 10	1		

M14

Injection equipment
 Einspritzausrstung
 Equipment d'injection
 Equipo de inyeccin
 Equipaggiamento di iniezione

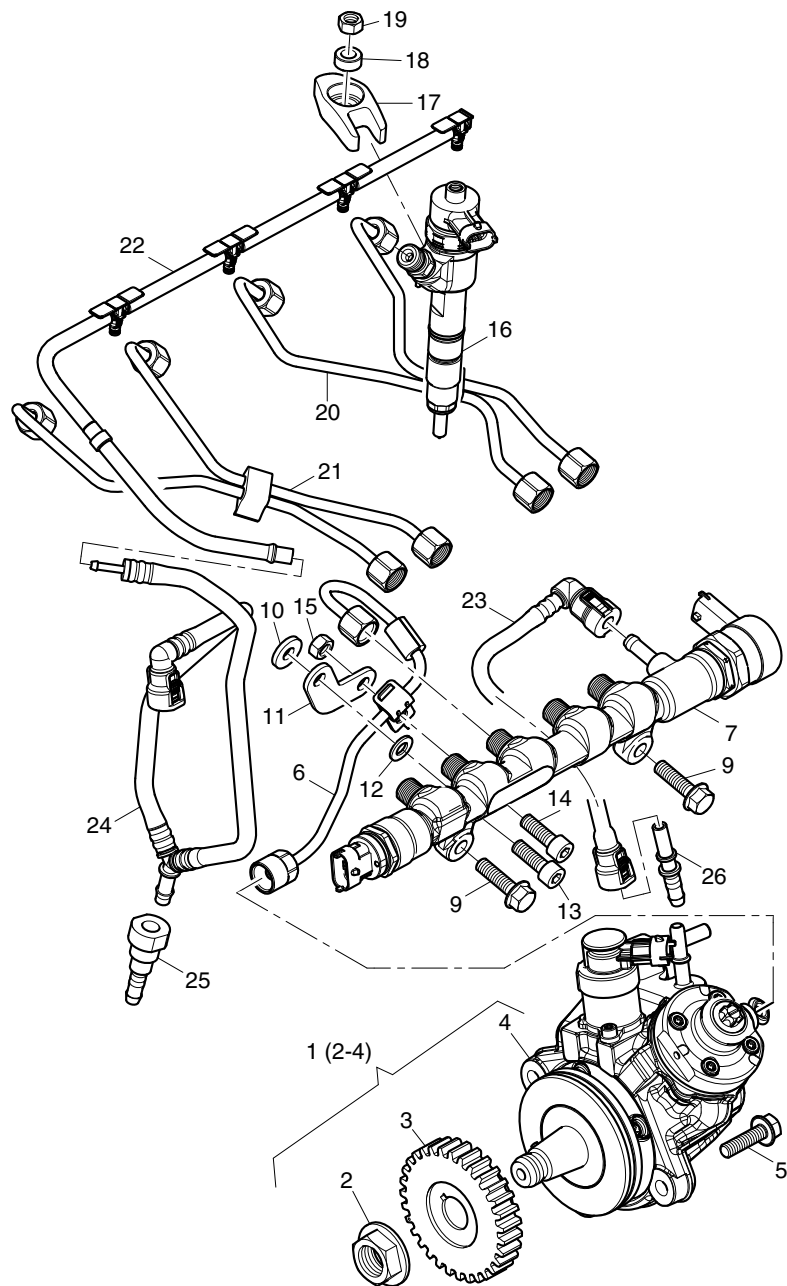

Fig.- No.	HATZ Ident-No.	Qty. Stck	W d / D	Notes Bemerkungen
4H50TIC				
1	0000 020 349 00	1		
2	-----	-		
3	-----	-		
4	-----	-		
5	0000 506 304 00	3		M 8 X 30 DIN6921 - 8.8 A2B
6	0000 020 337 00	1		
7	0000 042 931 00	1		
9	0000 506 304 00	2		M 8 X 30 DIN6921 - 8.8 A2B
10	0000 050 612 01	1		8,1 x 20 x 3
11	0000 043 002 00	1		
12	0000 501 481 00	1		8,4 DIN 125-St A3C
13	0000 503 663 00	1		M 8 x 20 DIN 912-8.8A3C
14	0000 503 663 00	1		M 8 x 20 DIN 912-8.8A3C
15	0000 503 353 00	1		M 8 SW 12 A3C
16	0000 042 937 00	4		
17	0000 043 006 00	4		
18	0000 040 357 00	4		
19	0000 501 480 00	4		M 8 DIN 934-8 A3C
20	0000 020 338 00	1		Injector 1+2
21	0000 020 339 00	1		Injector 3+4
22	0000 506 302 00	1		
23	0000 020 409 00	1		
24	0000 020 410 00	1		
25	0000 506 579 00	1		
26	0000 506 578 00	1		

Intermediate housing SAE5
 Anschlussgehäuse SAE 5
 Bride raccord SAE5
 Caja de conexión SAE5
 Flangiatura SAE 5

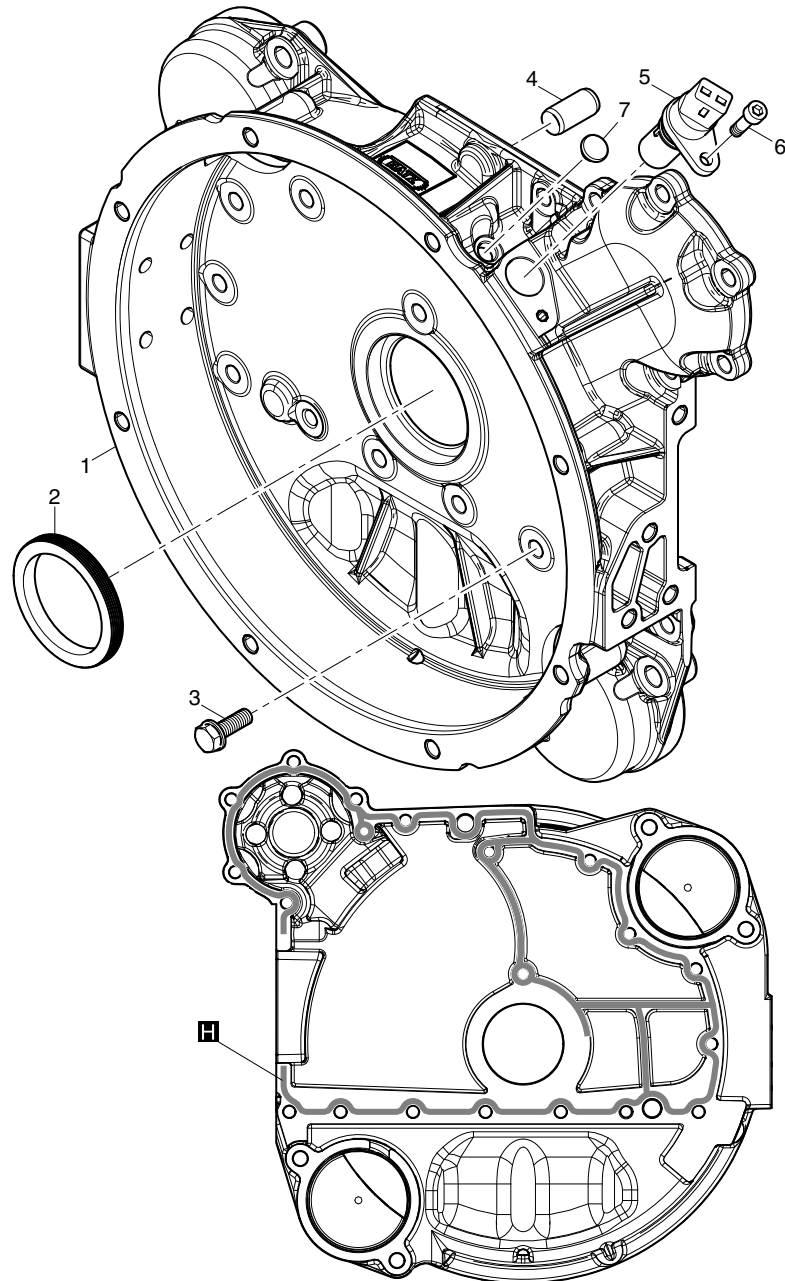
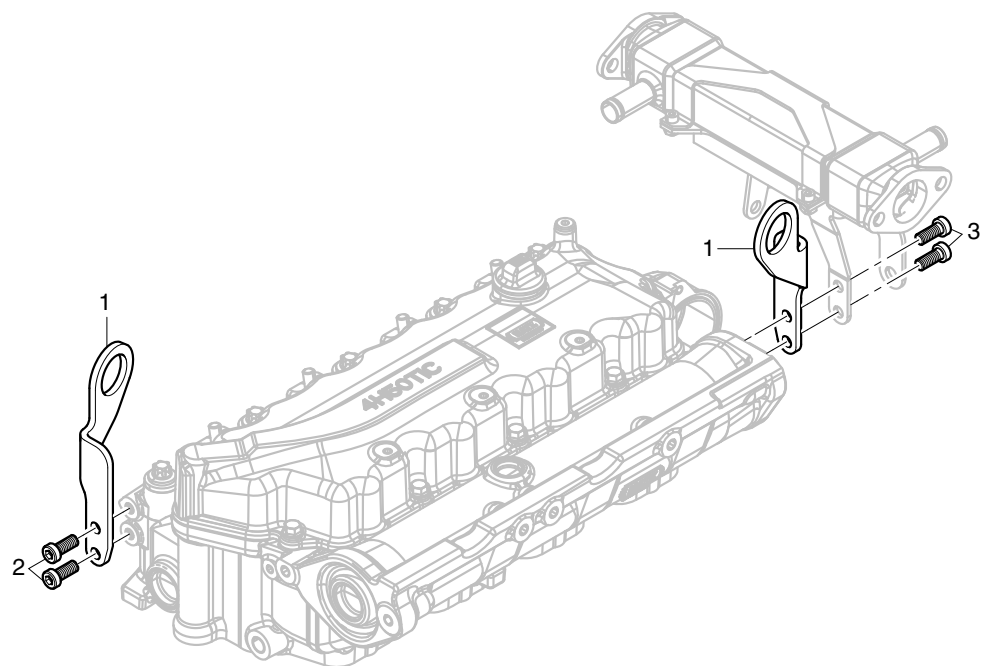

Fig.- No.	HATZ Ident-No.	Qty. Stück	W d / D	Notes Bemerkungen
4H50TIC				
1	0000 042 965 11	1		
2	0000 501 291 01	1		
3	0000 506 258 00	19		
4	0000 506 325 00	2		14 M 6 X 28 DIN 6325
5	0000 506 335 00	1		
6	0000 501 706 00	1		M 6 x 20 DIN 912-8.8A3C
7	0000 501 608 00	1		F 5 14x10,7x7,5

M30

Lifting device
Aufzugvorrichtung
Dispositiv de suspension
Dispositivo de suspension
Aufzugvorrichtung

Fig.- No.	HATZ Ident-No.	Qty. Stück	W d / D	Notes Bemerkungen
4H50TIC				
1	0000 042 992 01	2		
2	0000 503 663 00	2		M 8 x 20 DIN 912-8.8A3C
3	0000 501 715 00	2		M 8 x 25 DIN 912-8.8A3C



Crankcase breathing system
 Kurbelgehäuseentlüftung
 Reniflard
 Purgador
 Sfiato basamento

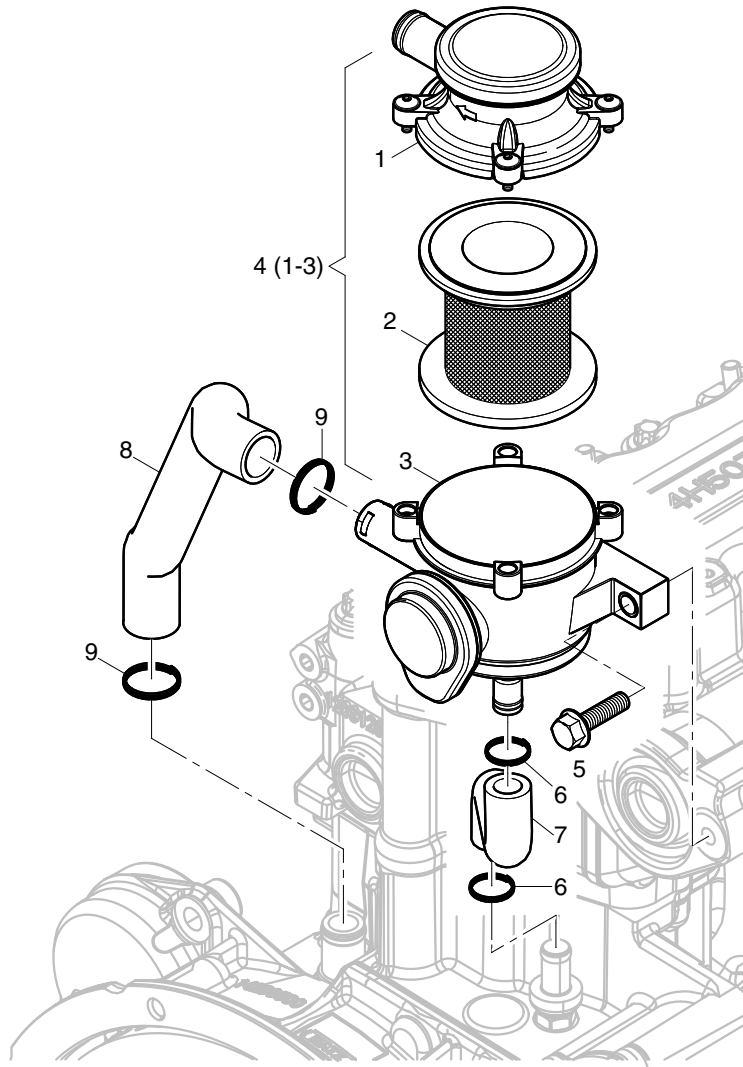

Fig.- No.	HATZ Ident-No.	Qty. Stück	W d / D	Notes Bemerkungen
4H50TIC				
1	-----	-		
2	0000 506 405 00	1		
3	-----	-		
4	0000 506 355 10	1		
5	0000 506 304 00	2		
6	0000 040 905 00	2		
7	0000 043 062 00	1		
8	0000 043 063 00	1		
9	0000 043 066 00	2		
				M 8 X 30 DIN6921 - 8.8 A2B

Exhaust-gas recirculation
 Abgasrückführung
 Recirculation gaz de escape
 Recirculacion gases de escape
 Ricircolo dei gas di scarico

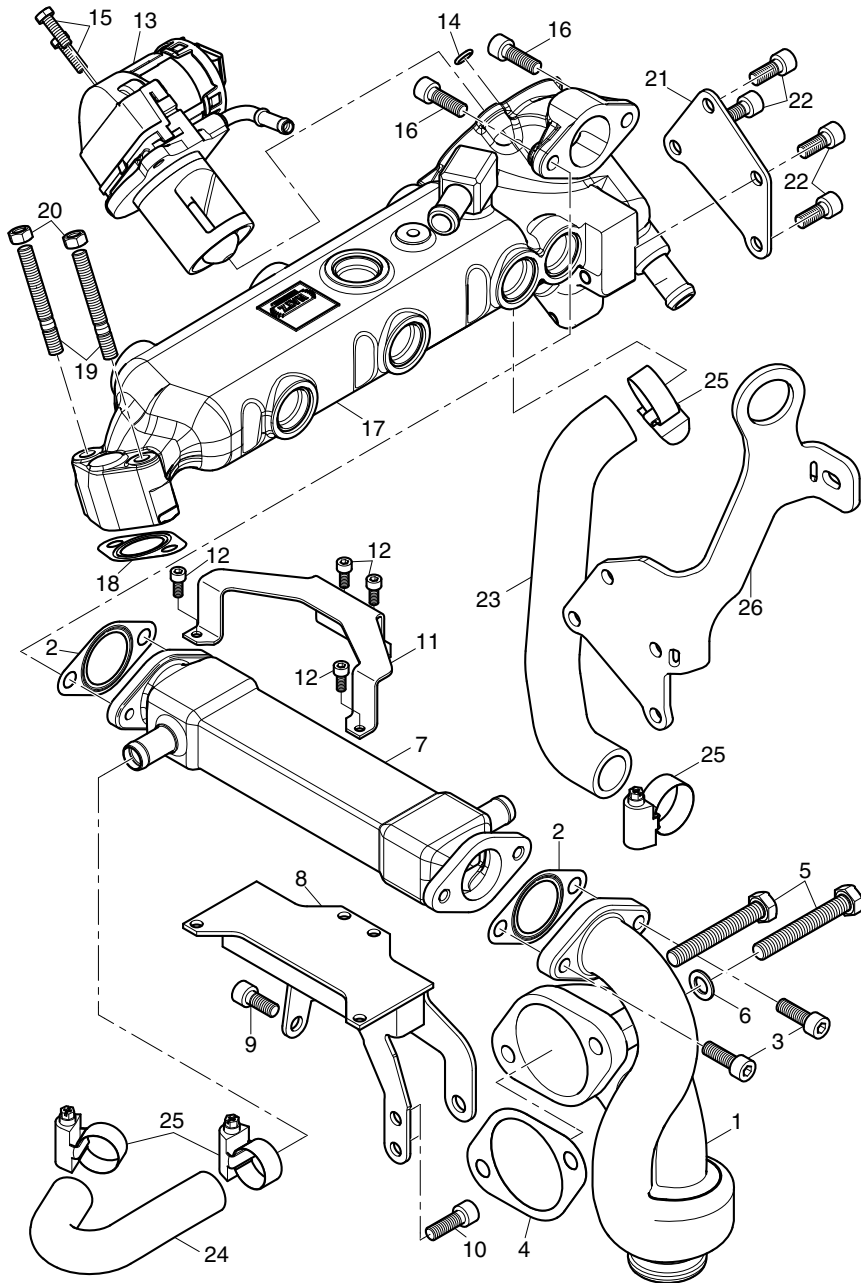

Fig.- No.	HATZ Ident-No.	Qty. Stück	W d / D	Notes Bemerkungen
4H50TIC				
1	0000 043 031 00	1		
2	0000 043 029 00	1		
3	0000 501 715 00	2		M 8 x 25 DIN 912-8.8A3C
4	0000 506 238 00	1		
5	0000 500 302 00	2		
6	0000 500 170 00	1		10,5 DIN 433 - St A3C
7	0000 506 321 00	1		
8	0000 020 363 00	1		
9	0000 503 663 00	1		M 8 x 20 DIN 912-8.8A3C
10	0000 501 715 00	2		M 8 x 25 DIN 912-8.8A3C
11	0000 043 030 00	1		
12	0000 502 745 00	4		M 5 x 12 DIN 912-8.8A3C
13	0000 506 288 10	1		
14	0000 400 224 01	1		8 x 2 FPM 75 MOLYKOT.
15	0000 502 079 00	2		M 6 x 20 DIN 933-8.8 A3C
16	0000 501 715 00	2		M 8 x 25 DIN 912-8.8A3C
17	0000 020 359 10	1		
18	0000 042 722 01	1		
19	0000 500 387 00	2		M 8 x 50 DIN 835 - 8.8 A3C
20	0000 400 284 00	2		VM 8 DIN 980-8 C3A
21	0000 043 067 00	0... 1		
22	0000 503 663 00	4		M 8 x 20 DIN 912-8.8A3C
23	0000 043 082 00	1		22x5
24	0000 043 085 10	1		
25	0000 506 412 00	4		20-32x13
26	0000 054 829 00	0... 1		

Fuel
Kraftstoff
Carburant
Combustible
Serbatoio

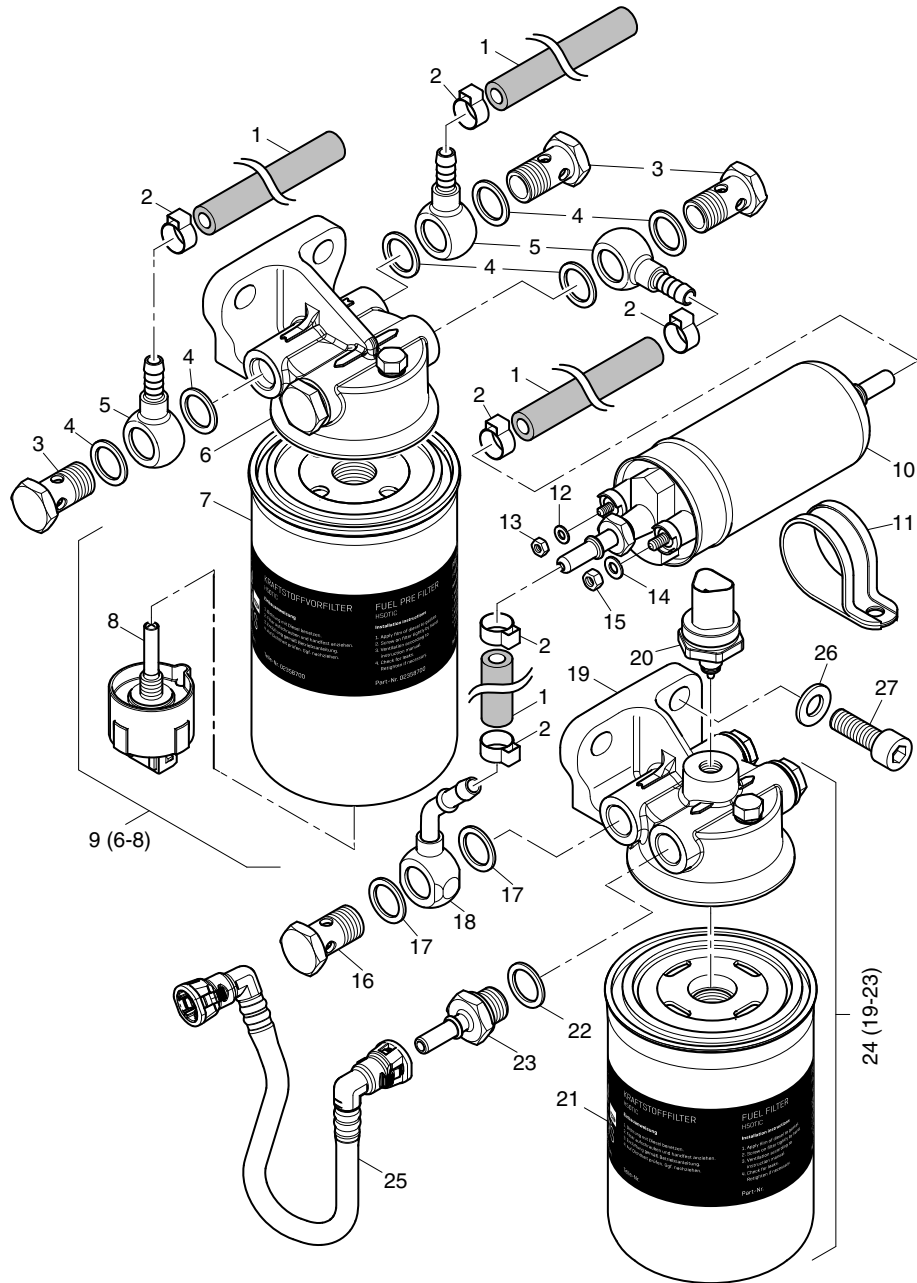

Fig.- No.	HATZ Ident-No.	Qty. Stück	W d / D	Notes Bemerkungen
4H50TIC				
1	0000 053 830 00	0... 4		8 x 5000mm
1	0000 054 184 00	0... 4		8 x 1000mm
2	0000 504 568 00	6		
3	0000 506 396 00	3		M 16 x 1,5
4	0000 506 471 00	6		A 16 x 22
5	0000 506 395 00	3		LW8 M16
6	-----	-		
7	0000 506 380 00	1		
8	0000 506 597 00	1		
9	0000 023 587 01	1		
10	0000 506 408 00	1		
11	0000 506 431 00	1		
12	0000 501 472 00	1		4,3 DIN 125 - A3C
13	0000 501 471 00	1		M4 DIN 934 - 8 A3C
14	0000 502 163 00	1		5,3 DIN 125-St A3C
15	0000 500 943 00	1		M 5 DIN 934-8 A3C
16	0000 506 396 00	1		M 16 x 1,5
17	0000 506 471 00	2		A 16 x 22
18	0000 020 408 00	1		
19	-----	-		
20	0000 506 337 00	1		
21	0000 506 381 00	1		
22	-----	-		
23	0000 043 118 00	-		
24	0000 023 588 00	1		
25	0000 020 401 00	1		
26	0000 501 459 00	2		10,5 DIN 125-St A3C
27	0000 500 934 00	2		M 10 x 30 DIN 912-8.8A3C

Z02a

Air filter
Luftfilter
Filtre à air
Filtro de aire
Filtro aria

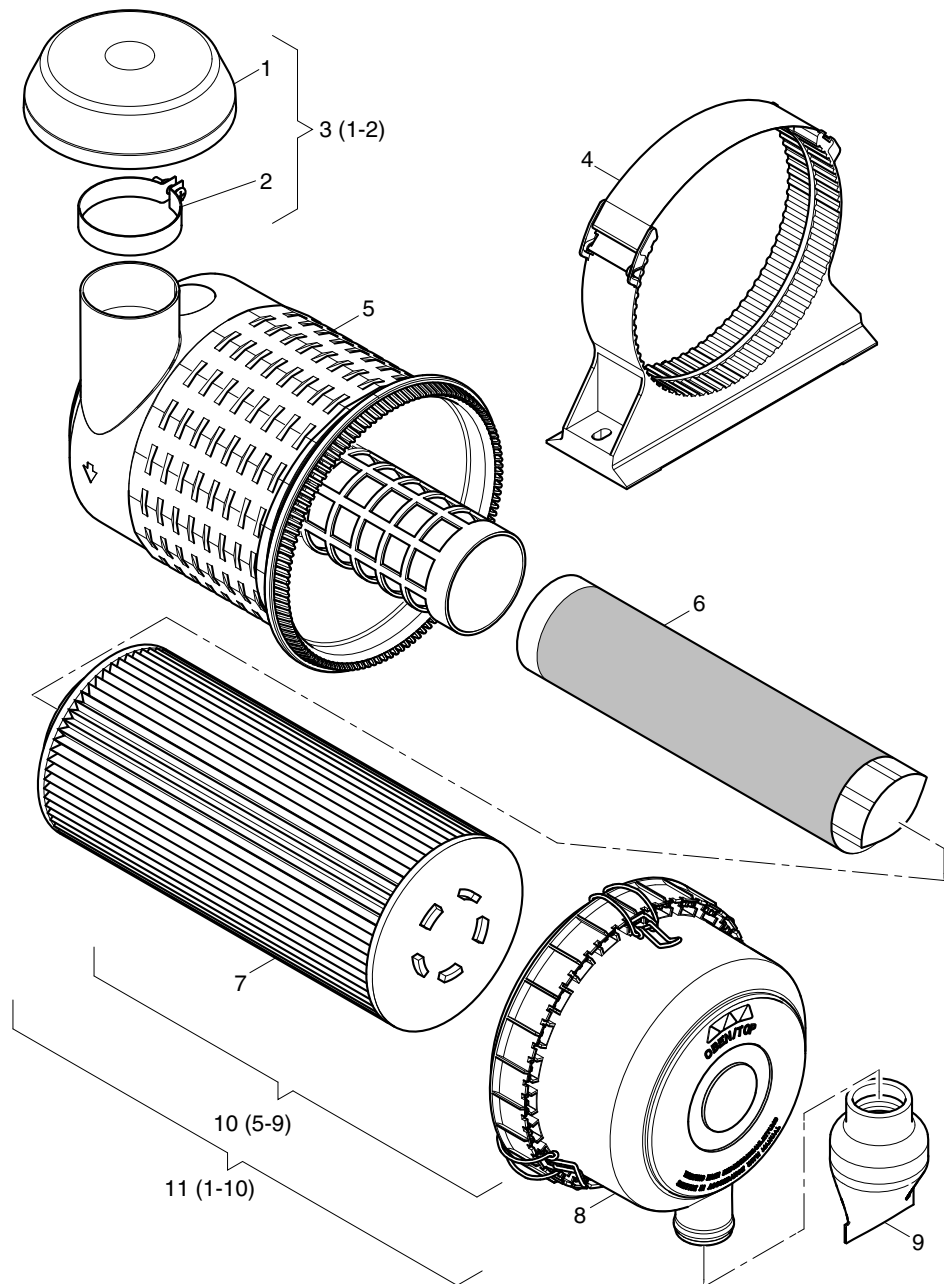

Fig.- No.	HATZ Ident-No.	Qty. Stück	W d / D	Notes Bemerkungen
4H50TIC				
1	-----	-		
2	-----	-		
3	0000 506 375 00	1		
4	0000 506 374 00	1		
5	-----	-		
6	0000 506 383 00	1		2 years
7	0000 506 382 00	1		
8	-----	-		
9	0000 506 605 00	1		
10	0000 506 373 00	1		
11	0000 023 669 00	1		

Z02b

Hose lines for intercooler
 Verschlauchung Ladeluft
 Conduites de tuyau p. intercooler
 tubos p. intercooler
 Tubo di intercooler

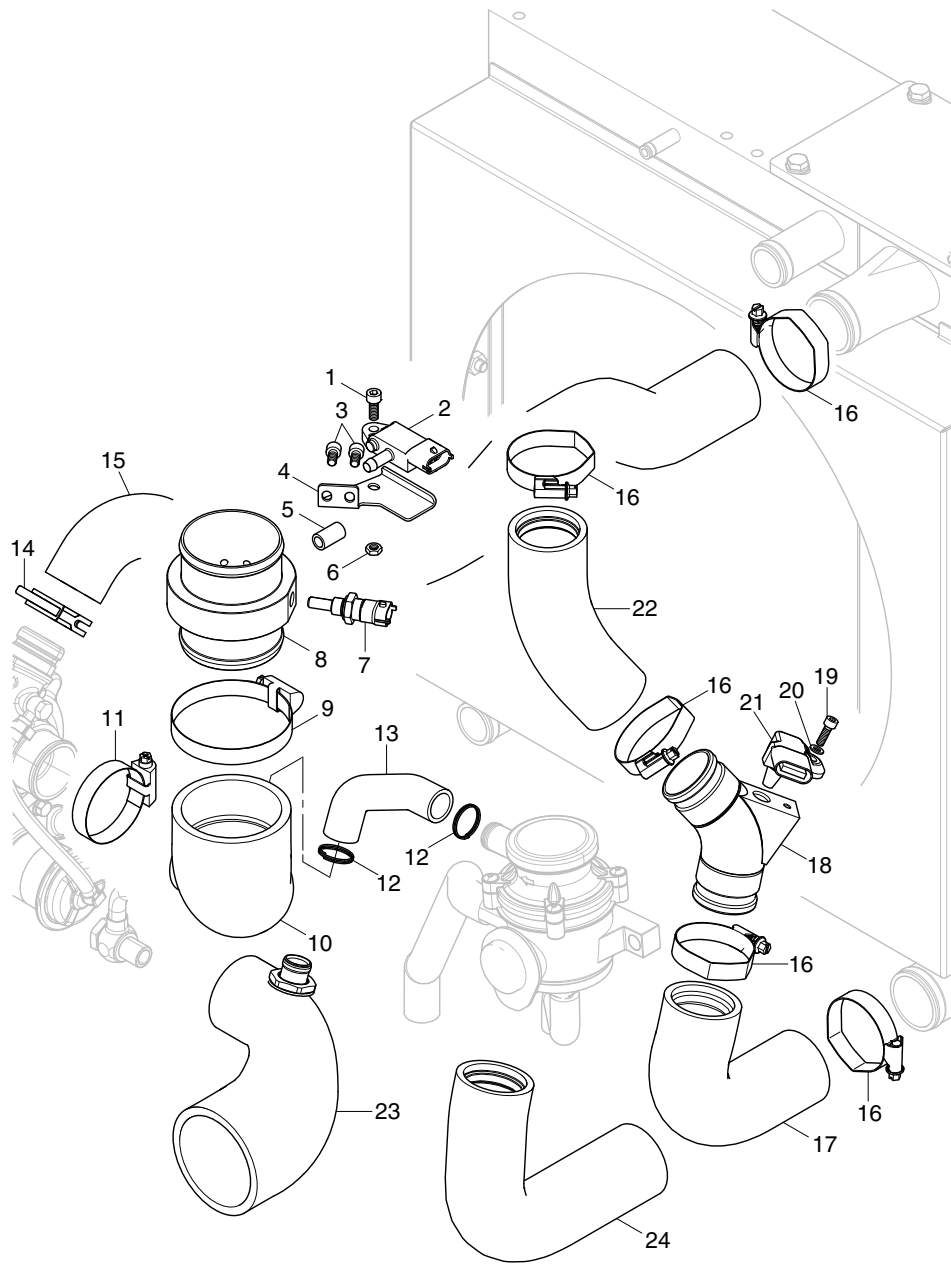

Fig.- No.	HATZ Ident-No.	Qty. Stück	W d / D	Notes Bemerkungen
4H50TIC				
1	0000 501 707 00	1		M 6 x 16 DIN 912-8.8A3C
2	0000 506 499 00	1		
3	0000 501 491 00	2		M 6 x 12 DIN 912-8.8A3C
4	0000 043 218 00	1		
5	0000 043 219 00	1		
6	0000 501 444 00	1		M 6 DIN 934 - 8 A3C
7	0000 506 336 00	1		
8	0000 043 217 00	1		
9	0000 506 409 00	1		
10	0000 020 470 10	1		vertical
11	0000 504 066 00	1		40 / 60
12	0000 043 066 00	2		
13	0000 043 079 11	1		
14	0000 506 351 00	1		
15	0000 043 050 00	1		
16	0000 506 352 00	5		40-60
17	0000 043 052 00	0... 1		external exp.tank
18	0000 043 165 00	1		
19	0000 504 853 00	1		M 5x 16 DIN 912 8.8A3C
20	0000 502 163 00	1		5,3 DIN 125-St A3C
21	0000 506 334 00	1		
22	0000 043 051 00	1		
23	0000 020 474 00	1		horizontal
24	0000 043 250 00	0... 1		internal exp.tank

Z03a

Exhaust manifold, turbo charger
 Abgaskrümmter, Turbolader
 Tube de echappement, Turbo
 Tubo de escape, Turbo
 Collettore di scarico, Turbo

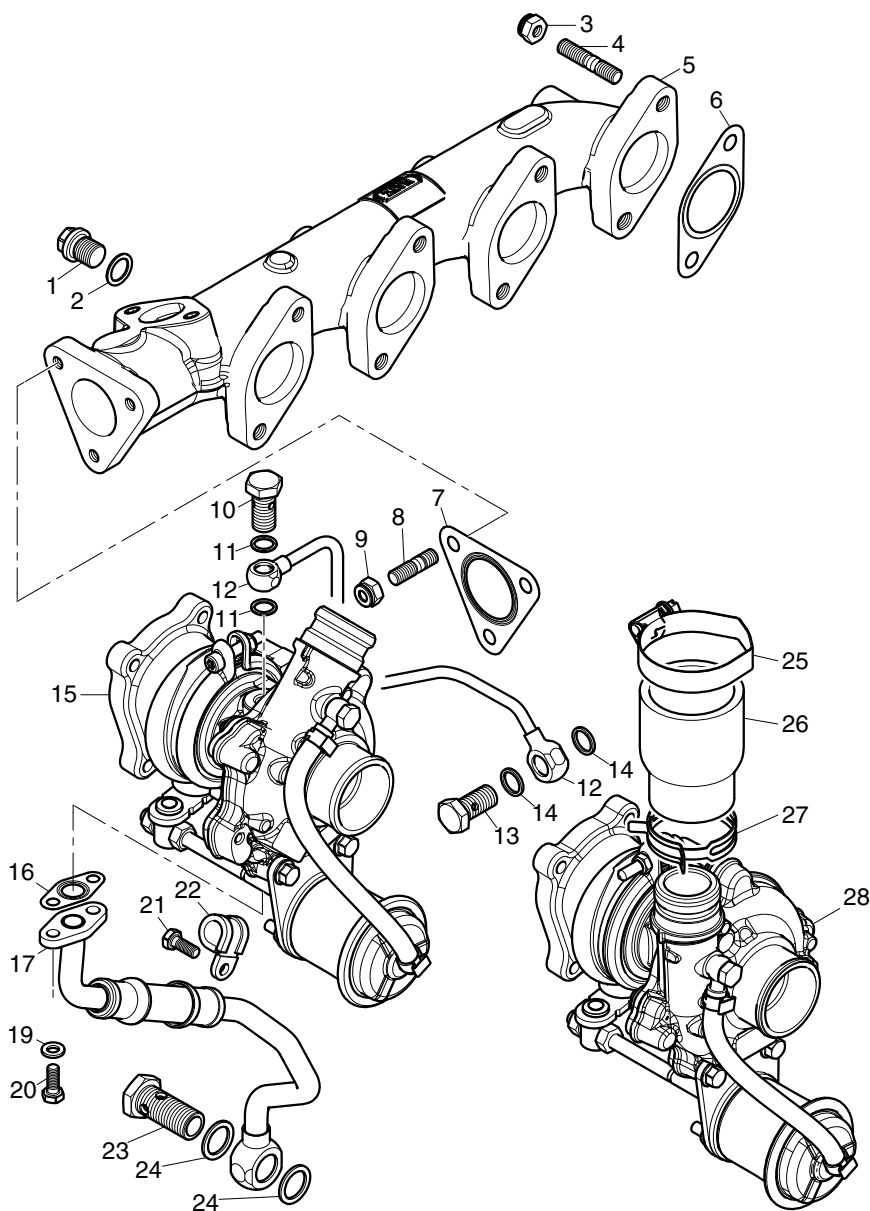

Fig.- No.	HATZ Ident-No.	Qty. Stück	W d / D	Notes Bemerkungen
4H50TIC				
1	0000 500 447 00	1		R 1/4 DIN 910 - 5.8 A3C
2	0000 032 288 00	1		
3	0000 400 284 00	8		VM 8 DIN 980-8 C3A
4	0000 502 319 00	8		M 8 x 25 DIN 835-8.8 A3C
5	0000 042 966 01	1		
6	0000 054 348 00	4		
7	0000 043 003 00	1		
8	0000 502 107 00	3		
9	0000 400 284 00	3		VM 8 DIN 980-8 C3A
10	0000 500 063 00	1		8-3 DIN 7643
11	0000 500 011 00	2		A 12 x 15,5 DIN 7603-Cu
12	0000 020 340 00	1		
13	0000 501 697 00	1		
14	0000 500 624 00	2		A 10 x 13,5 DIN 7603-Cu
15	0000 506 331 00	0... 1		45°
16	0000 043 004 00	1		
17	0000 020 351 00	1		
19	0000 501 445 00	2		6,4 DIN 125-St A3C
20	0000 501 771 00	2		M 6 x 16 DIN 933-8.8 A3C
21	0000 501 771 00	1		M 6 x 16 DIN 933-8.8 A3C
22	0000 506 306 00	1		
23	0000 505 589 00	1		10-3 DIN 7643-3 TYPE 8093
24	0000 500 013 00	2		A 16 x 22 DIN 7603 - Cu
25	0000 506 352 00	0... 1		40-60
26	0000 043 049 10	0... 1		
27	0000 506 384 00	0... 1		42-44,5
28	0000 506 305 00	0... 1		90°

Z03b

Oxidation catalyst
 Oxidationskatalysator
 Épurateur oxycatalytique
 Catalizador de oxidación
 Catalizzatore ossidazione

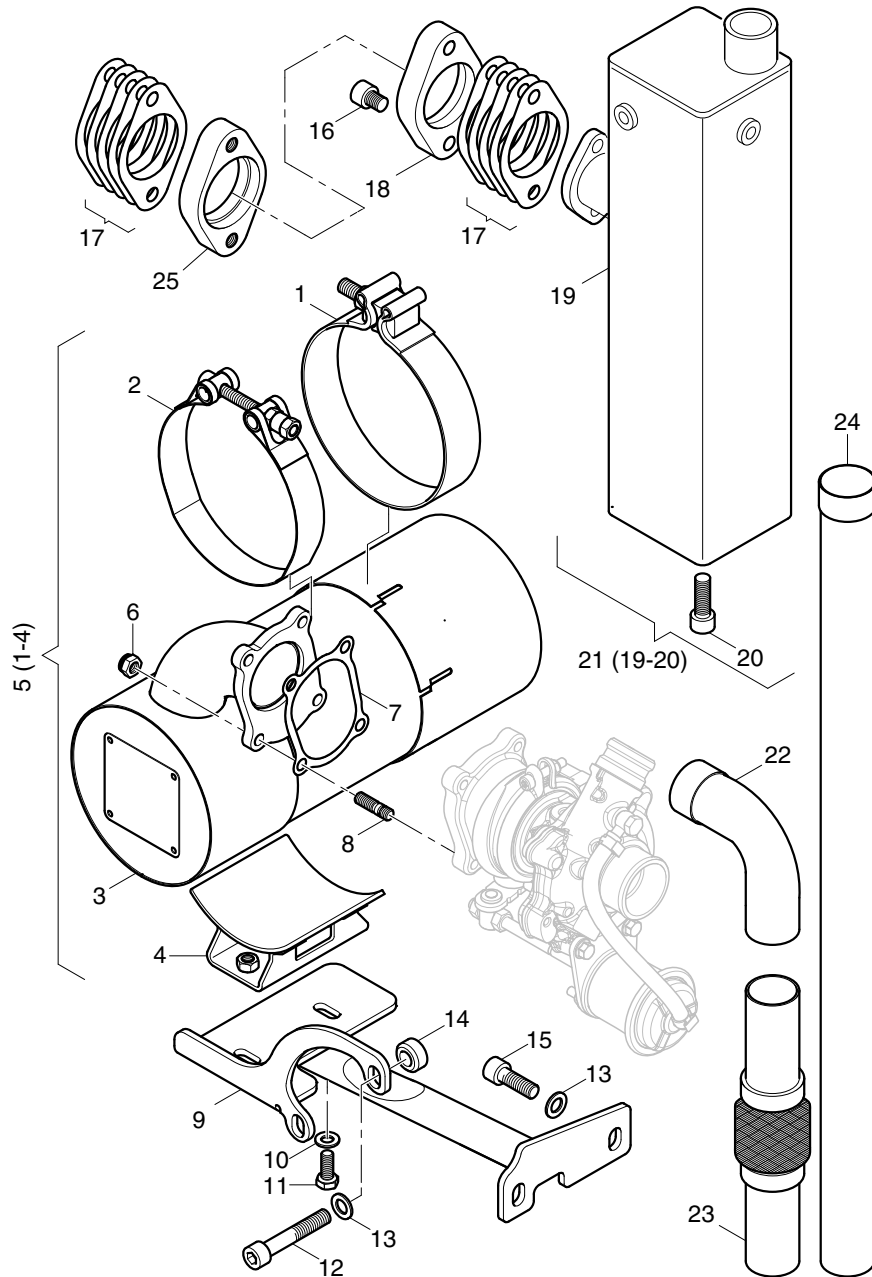

Fig.- No.	HATZ Ident-No.	Qty. Stück	W d / D	Notes Bemerkungen
4H50TIC				
1	0000 490 964 00	1		
2	0000 490 965 00	1		
3	-----	-		
4	0000 490 963 00	1		
5	0000 023 367 00	1		
6	0000 400 284 00	4		VM 8 DIN 980-8 C3A
7	0000 054 222 00	1		
8	0000 506 242 00	4		
9	0000 023 368 01	1		
10	0000 501 481 00	2		8,4 DIN 125-St A3C
11	0000 501 354 00	2		M 8 x 20 DIN 933-8.8 A3C
12	0000 500 552 00	2		M 10 x 60 DIN 912-8.8A3C
13	0000 500 170 00	4		10,5 DIN 433 - St A3C
14	0000 054 226 00	2		
15	0000 500 934 00	2		M 10 x 30 DIN 912-8.8A3C
16	0000 502 250 00	2		M10 x 30 DIN 912-10.9C4P
17	0000 016 037 00	2		
18	0000 054 164 00	1		
19	-----	-		
20	0000 501 389 00	4		M 8 x 12 DIN 912-8.8C4P
21	0000 011 091 01	1		
22	0000 506 547 00	0... 1		Ø55x90°
23	0000 506 545 00	0... 1		Ø55x340mm
24	0000 506 546 00	0... 1		Ø55x980mm
25	0000 038 278 00	1		

Z03c

Oxidation catalyst external
 Oxidationskatalysator extern
 Épurateur oxycatalytique externe
 Catalizador de oxidación externo
 Catalizzatore ossidazione esterno

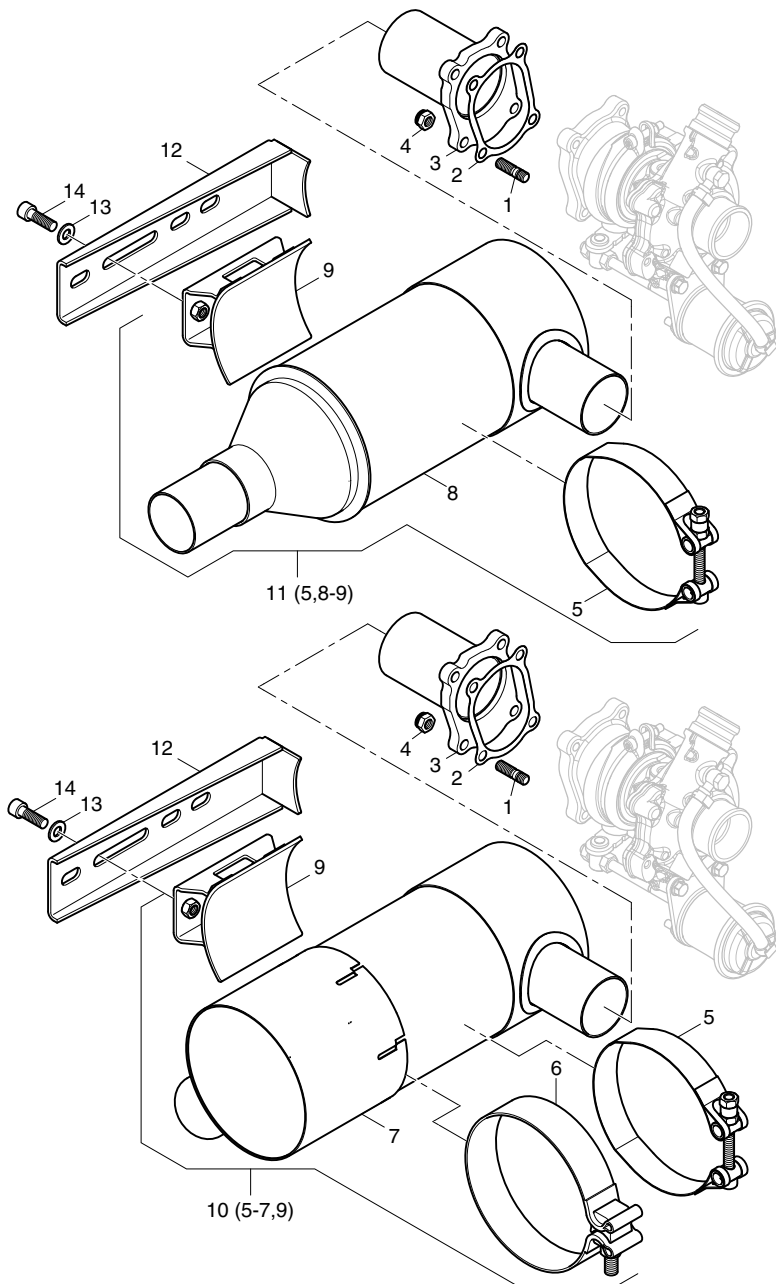

Fig.- No.	HATZ Ident-No.	Qty. Stück	W d / D	Notes Bemerkungen
4H50TIC				
1	0000 506 242 00	4		
2	0000 054 222 00	1		
3	0000 020 498 00	1		
4	0000 400 284 00	4		VM 8 DIN 980-8 C3A
5	0000 490 965 00	1		
6	0000 490 964 00	1		
7	-----	-		
8	-----	-		
9	0000 490 963 00	1		
10	0000 020 421 00	1		
11	0000 020 420 00	1		
12	0000 054 419 00	1		
13	0000 501 481 00	2		8,4 DIN 125-St A3C
14	0000 501 715 00	2		M 8 x 25 DIN 912-8.8A3C

Z05a

Pre-glowing device
 Vorglühanlage
 Dispositiv de pre-chauffage
 Dispositivo de precalentamiento
 Preriscaldo

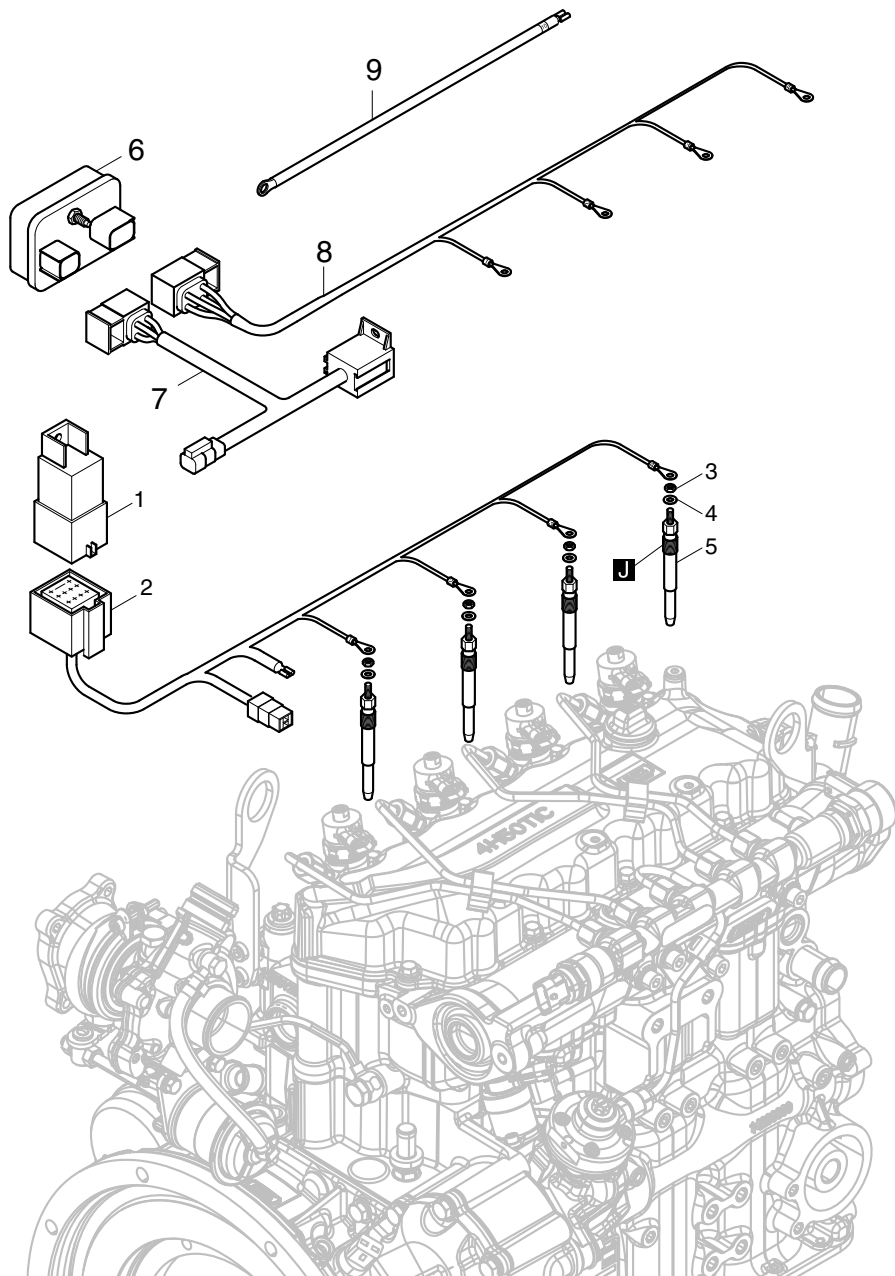

Fig.- No.	HATZ Ident-No.	Qty. Stück	W d / D	Notes Bemerkungen
4H50TIC				
1	0000 506 266 00	1		12V
2	0000 023 566 11	1		12V
3	0000 501 472 00	4		4,3 DIN 125 - A3C
4	0000 501 471 00	4		M4 DIN 934 - 8 A3C
5	0000 506 265 00	4		12V
5	0000 506 486 01	4		24V
6	0000 506 581 00	1		24V
7	0000 024 167 00	1		
8	0000 024 166 00	1		
9	0000 024 168 00	1		

Z05b

Starter, alternator
 Starter, Generator
 Démarreur, alternateur
 Arrancador, alternador
 Motorino avviamento, alternatore

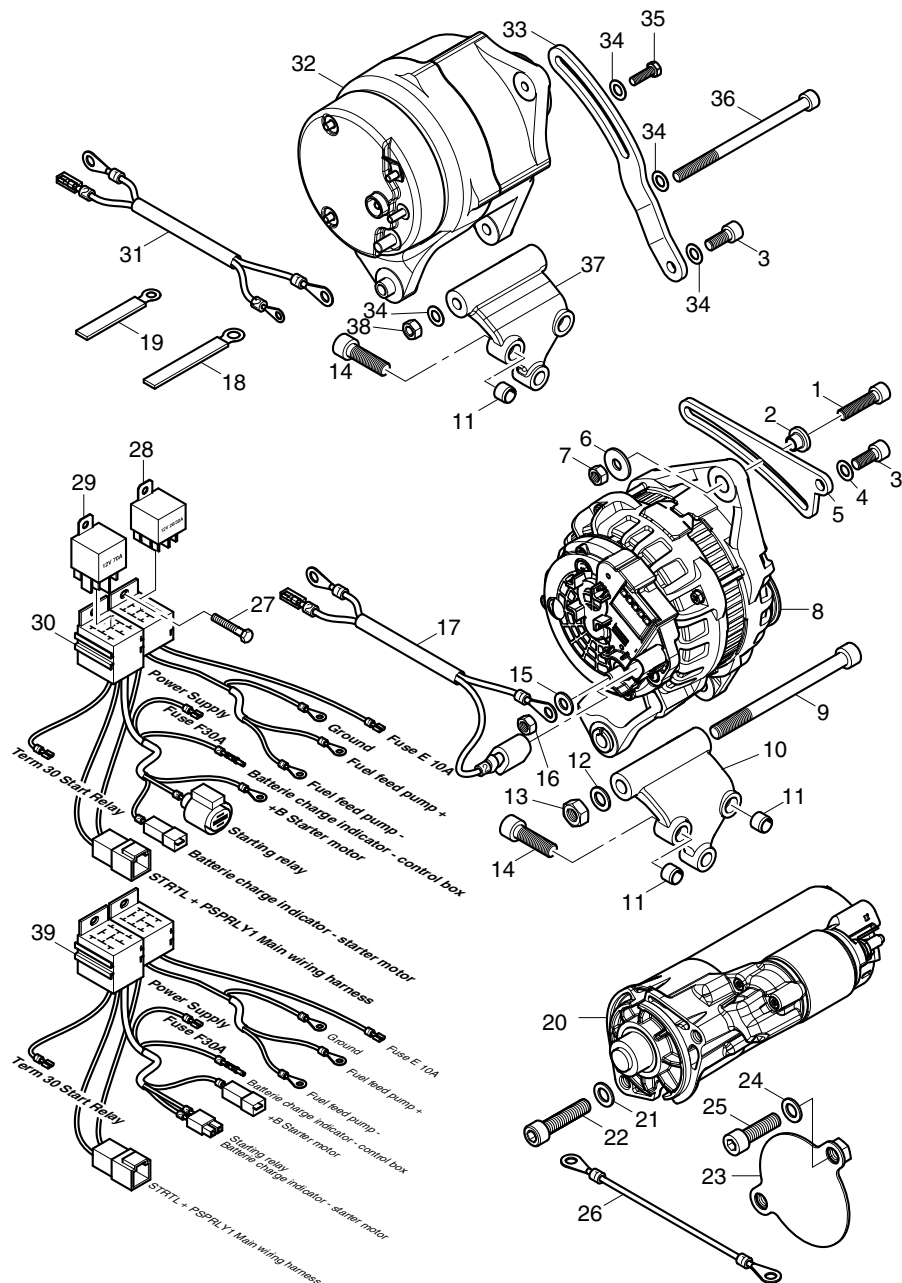

Fig.- No.	HATZ Ident-No.	Qty. Stück	W d / D	Notes Bemerkungen
4H50TIC				
1	0000 501 830 00	1		M 8 x 35 DIN 912-8.8A3C
2	0000 042 957 00	1		
3	0000 503 663 00	1		M 8 x 20 DIN 912-8.8A3C
4	0000 501 481 00	1		8,4 DIN 125-St A3C
5	0000 043 037 00	1		
6	0000 500 629 00	1		8,4 DIN 9021 St A3C
7	0000 501 480 00	1		M 8 DIN 934-8 A3C
8	0000 506 245 00	1		14V - 110A
9	0000 504 038 00	1		M 10 x130 DIN 912-8.8A3C
10	0000 043 036 00	1		
11	0000 505 023 00	2		12 x 10 DIN 7346
12	0000 500 170 00	1		10,5 DIN 433 - St A3C
13	0000 501 458 00	1		M 10 DIN 934-8 A3C
14	0000 503 278 00	3		M 10 x 35 DIN 912-8.8A3C
15	0000 500 168 00	1		8,4 DIN 125-MS
16	0000 500 230 00	1		M 8 DIN 934-MS
17	0000 023 745 01	1		12V
18	0000 050 239 00	2		
19	0000 050 012 00	2		
20	0000 506 246 00	0... 1		12V
20	0000 506 485 00	0... 1		24V
21	0000 500 170 00	2		10,5 DIN 433 - St A3C
22	0000 500 547 00	2		M 10 x 45 DIN 912-8.8A3C
23	0000 023 563 00	1		
24	0000 500 170 00	2		10,5 DIN 433 - St A3C
25	0000 503 278 00	2		M 10 x 35 DIN 912-8.8A3C
26	0000 023 384 00	1		
27	0000 500 942 00	2		M 5 x 10 DIN 933 - 8.8 A3C
28	0000 502 777 01	0... 1		12V - 20/30A
28	0000 502 778 01	0... 1		24V - 10/20A
29	0000 504 327 00	0... 1		12V - 70A
29	0000 504 540 01	0... 1		24V - 40A
30	0000 023 746 03	1		Starterposition LOW
31	0000 023 962 00	1		24V
32	0000 506 543 00	1		28V - 65A
33	0000 043 228 00	1		
34	0000 500 951 00	4		A 8 DIN 137 A3C
35	0000 502 079 00	1		M 6 x 20 DIN 933-8.8 A3C
36	0000 504 630 00	1		M 8 x130 DIN 912-8.8A3C
37	0000 043 229 00	1		
38	0000 023 383 10	1		Starterposition HIGH
38	0000 503 353 00	1		M 8 SW 12 A3C
39	0000 023 383 00	1		

Z05c

Control unit, Wiring harness - engine
 Steuergerät, Motorkabelbaum
 Dispositif de controle, Faisceau électrique - moteur
 Dispositivo de control, Mazo de cable - motor
 Centralina elettrica, Fascio di cablaggio - motore

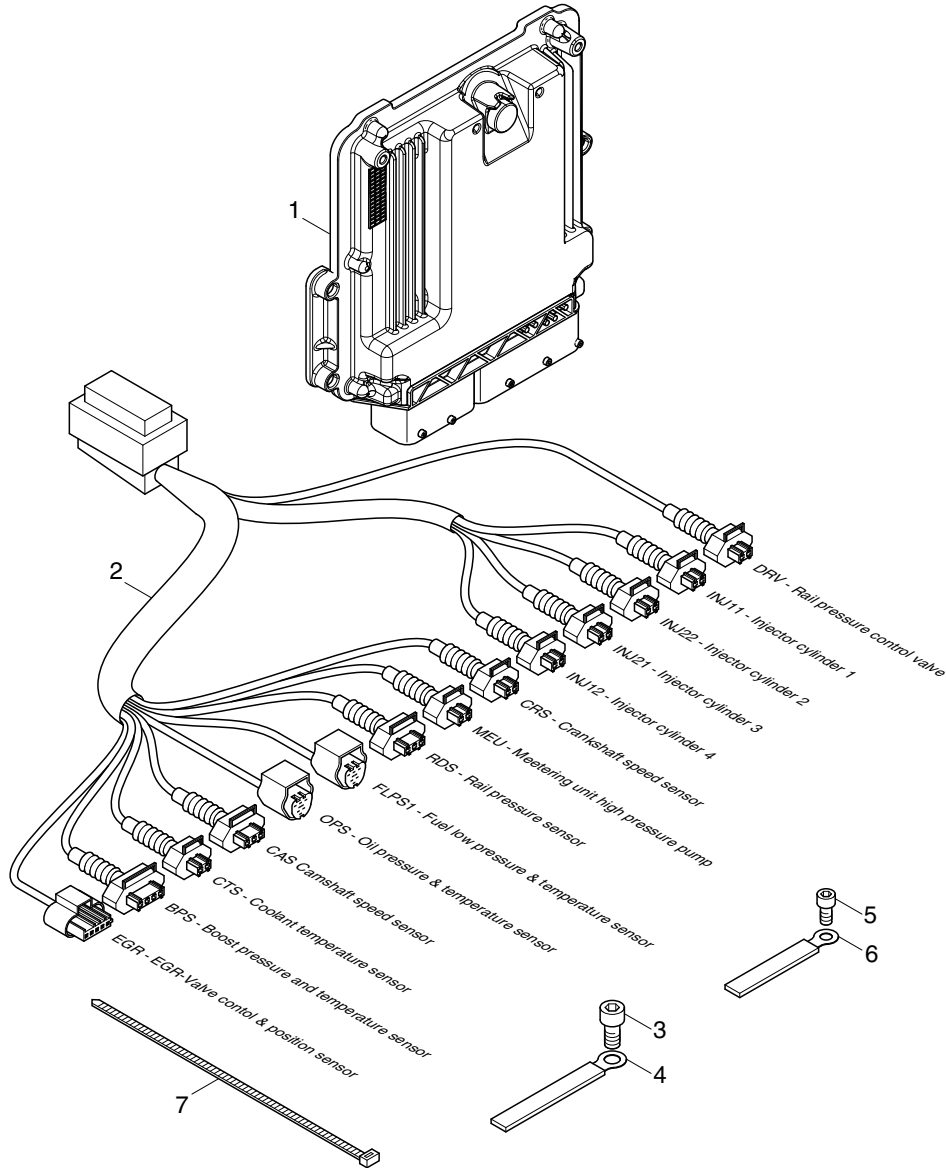

Fig.- No.	HATZ Ident-No.	Qty. Stück	W d / D	Notes Bemerkungen
4H50TIC				
1	0000 023 686 01	1		EngineNo needed!
2	0000 506 421 00	1		
3	0000 501 654 00	2		M 8 x 16 DIN 912-8.8A3C
4	0000 050 239 00	2		
5	0000 501 491 00	7		M 6 x 12 DIN 912-8.8A3C
6	0000 050 012 00	7		
7	0000 504 395 00	10		2,6 x 200 mm Black

Z05d

Wiring harness - chassis
 Chassis-Kabelbaum
 Faisceau électrique - chassis
 Mazo de cable - chasis
 Fascio di cablaggio - châssis

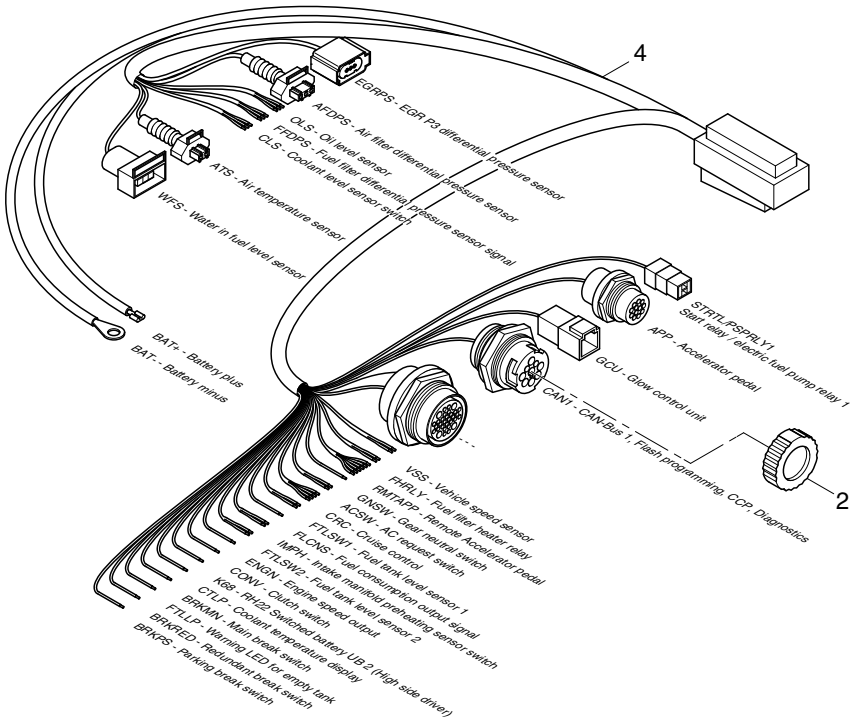
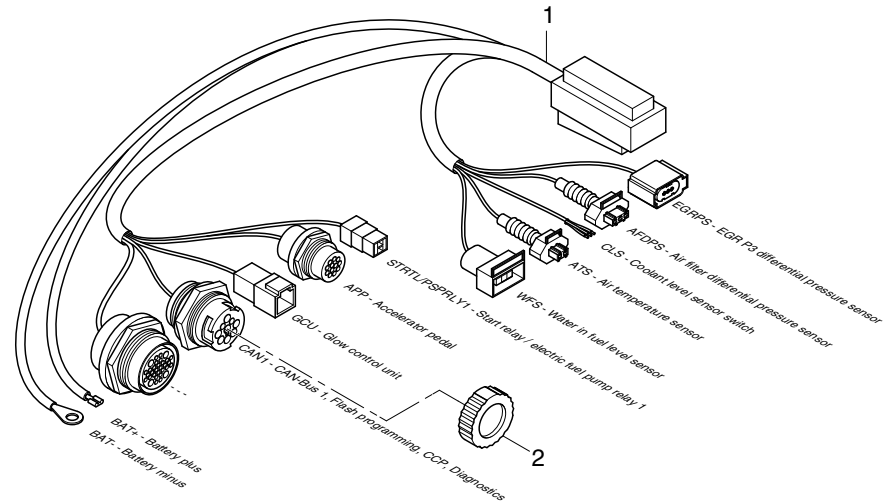

Fig.- No.	HATZ Ident-No.	Qty. Stück	W d / D	Notes Bemerkungen
--------------	-------------------	---------------	------------	----------------------

4H50TIC

1	0000 506 422 01	-		MIN.
2	0000 506 525 00	1		
4	0000 506 423 00	1		

Z05e

Fusebox, Speed control
 Sicherungskasten, Drehzahlverstellung
 coffret de fusibles, reglage regime
 caja de fusibles, Ajuste de revoluciones
 quadro dei fusibili, Regolatore di giri

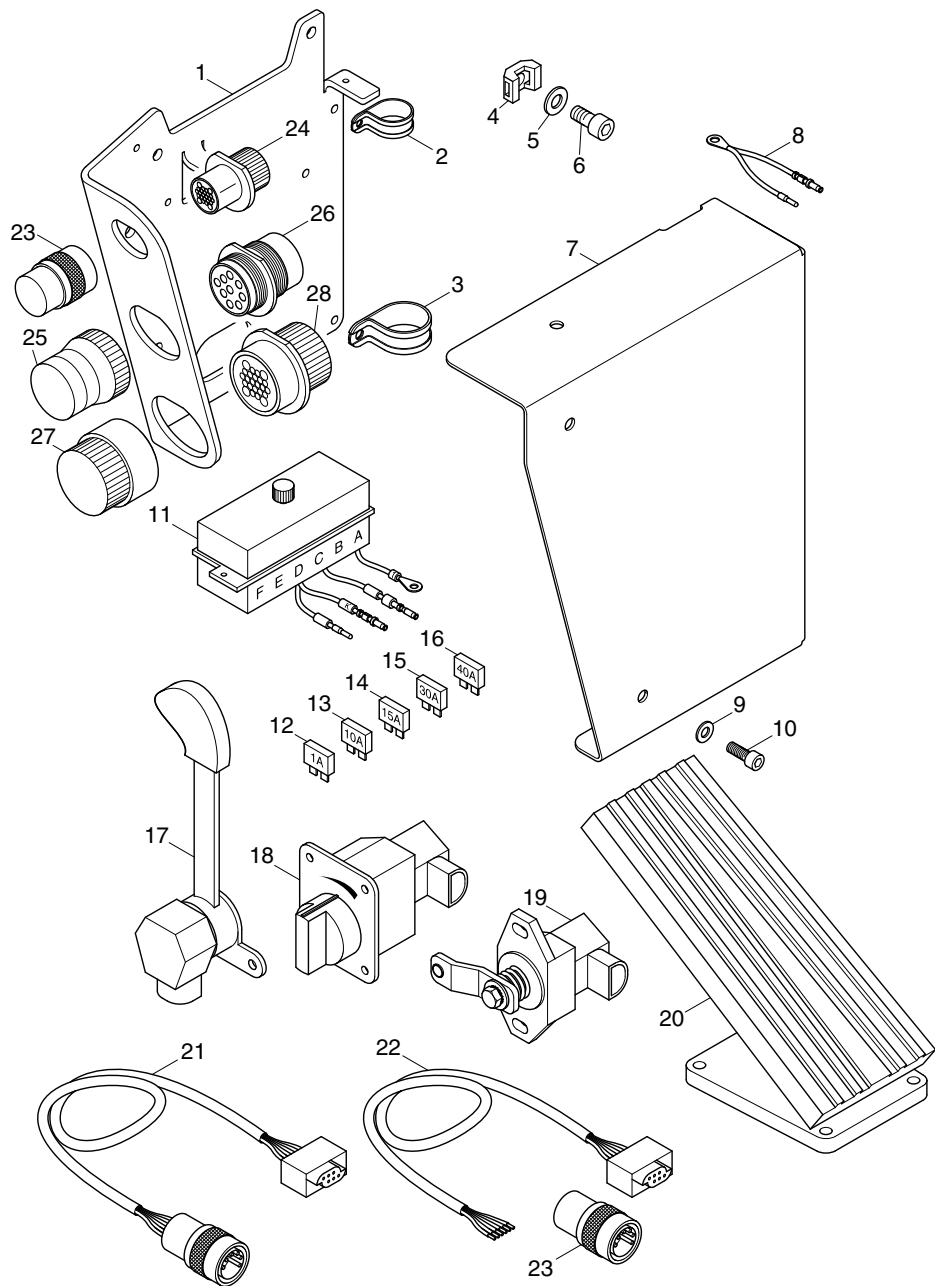

Fig.- No.	HATZ Ident-No.	Qty. Stück	W d / D	Notes Bemerkungen
4H50TIC				
1	0000 054 435 01	1		
2	0000 501 903 10	1		
3	0000 506 487 00	1		
4	0000 504 902 00	3		
5	0000 501 481 00	2		8,4 DIN 125-St A3C
6	0000 501 654 00	2		M 8 x 16 DIN 912-8.8A3C
7	0000 054 833 00	1		
8	0000 023 845 00	1		
9	0000 501 445 00	5		6,4 DIN 125-St A3C
10	0000 501 707 00	5		M 6 x 16 DIN 912-8.8A3C
11	0000 023 809 00	1		
12	0000 506 483 00	1		1 A
13	0000 504 593 00	1		10 A
14	0000 504 304 00	1		15 A
15	0000 504 307 00	1		30 A
16	0000 504 330 00	1		40 A
17	0000 506 493 00	1		
18	0000 506 494 00	1		
19	0000 506 496 00	1		
20	0000 506 495 00	1		
21	-----	1		3m
22	0000 506 497 00	1		1000mm
23	0000 023 941 00	1		acc.pedal
24	0000 024 066 00	1		acc.pedal
25	0000 023 943 00	1		diagnosis
26	0000 024 067 00	1		diagnosis
27	0000 023 944 00	1		customer control / dashboard
28	0000 024 065 00	1		customer control / dashboard

Engine brackets
 Motorfüsse
 Pieds de moteur
 Soportes del motor
 Piedini del motore

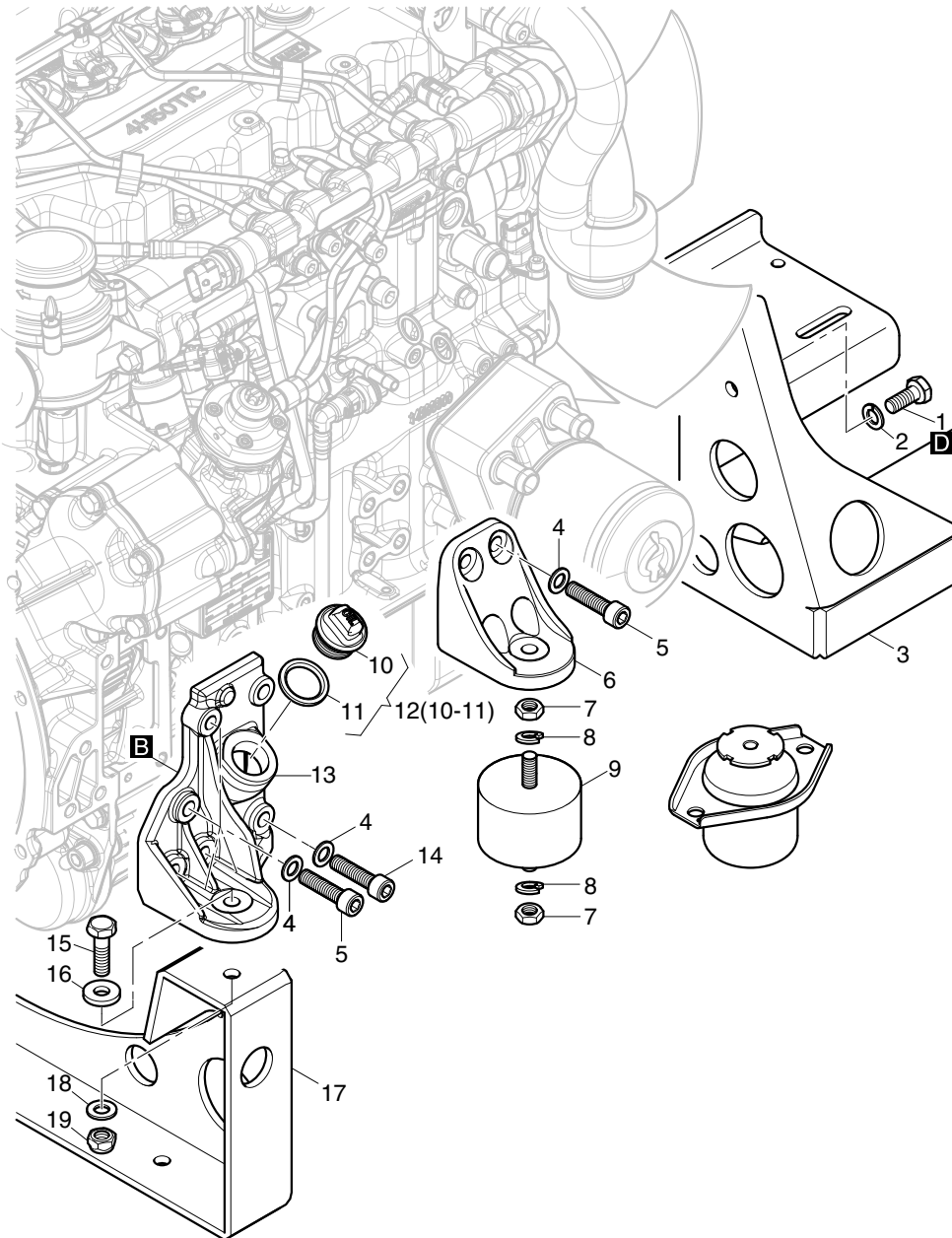

Fig.- No.	HATZ Ident-No.	Qty. Stück	W d / D	Notes Bemerkungen
4H50TIC				
1	0000 501 364 00	6		M 10 x 25 DIN 933 - 8.8 A3C
2	0000 501 356 00	6		10 DIN 128 A3C
3	0000 054 828 00	1		
4	0000 500 170 00	10... 18		10,5 DIN 433 - St A3C
5	0000 500 546 00	7... 16		M 10 x 40 DIN 912 - 8.8
6	0000 043 040 00	1... 3		
7	0000 501 458 00	8		M 10 DIN 934-8 A3C
8	0000 501 356 00	8		10 DIN 128 A3C
9	0000 502 603 00	4		65 SH 9
10	-----	-		
11	0000 041 250 00	1		26 x 35 x3
12	0000 016 131 00	1		
13	0000 043 041 01	1		
14	0000 500 544 00	2		M 10 x 35 DIN 912-8.8
15	0000 503 276 00	2		M 10 x 35 DIN 933 - 8.8 A3C
16	0000 500 706 00	2		10,5 x 25 x 4 DIN 7349 A3C
17	0000 054 827 00	1		
18	0000 501 459 00	2		10,5 DIN 125-St A3C
19	0000 400 286 00	2		VM 10 DIN 980-8 C3A

Z07a

Oil sump, oil cooler, dipstick
 Ölwanne, Ölkühler, Tauchstab
 Carter d'huile, radiateur d'huile, Jauge
 Carter de aceite, radiador de aceite, varilla
 Coppa olio, radiatore dell'olio, asta

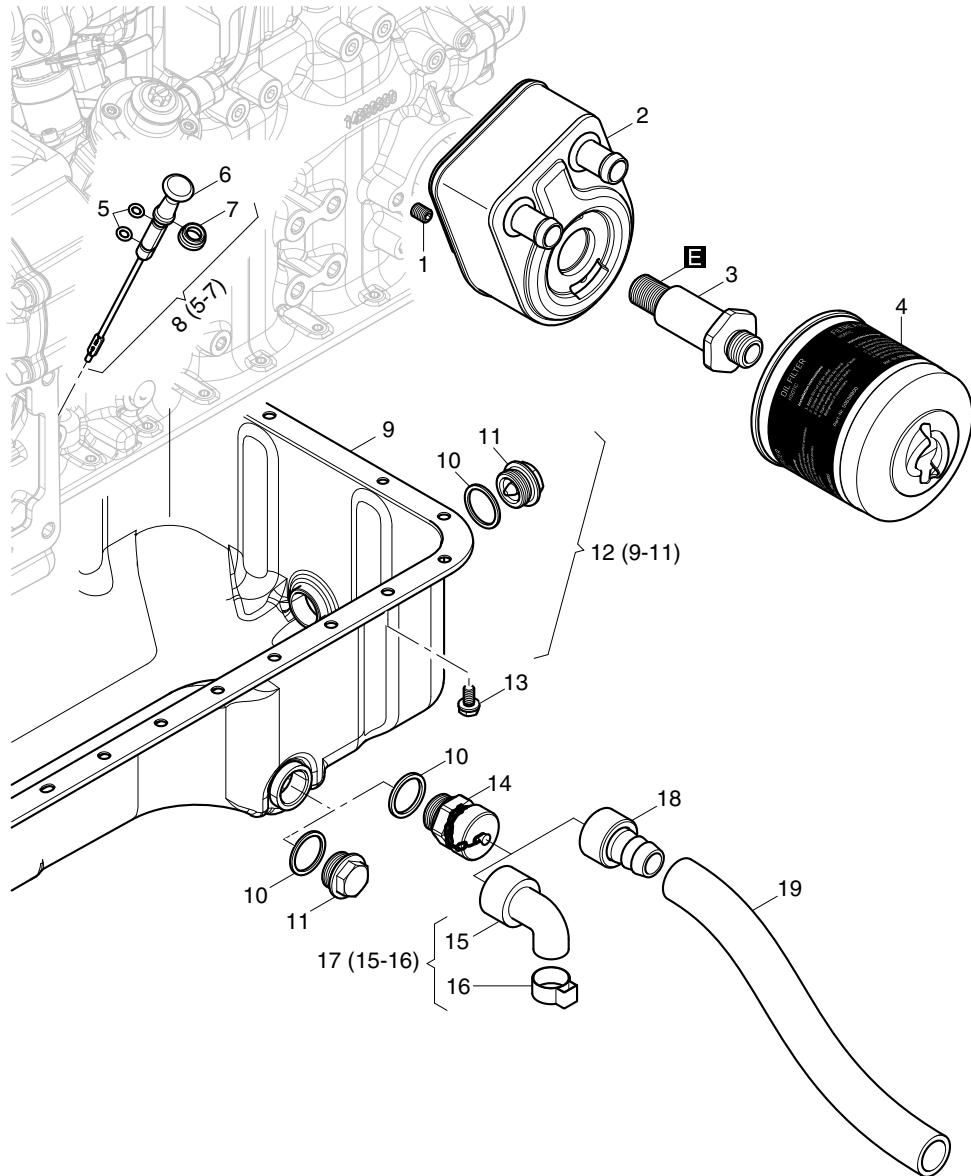

Fig.- No.	HATZ Ident-No.	Qty. Stück	W d / D	Notes Bemerkungen
4H50TIC				
1	0000 505 306 00	1		M 8 x 10 DIN 913 - 45H-A3C-KL
2	0000 506 354 10	1		
3	0000 043 047 00	1		
4	0000 506 388 00	1		
5	0000 400 220 00	2		5 x 2
6	-----	-		
7	0000 040 845 00	1		
8	0000 020 335 00	1		
9	-----	-		
10	0000 500 016 00	2		A 22 x 27 DIN 7603 Cu
11	0000 503 731 00	2		AM22x1,5DIN7604A3C MAGN.
12	0000 020 322 00	1		
13	0000 503 410 00	27		M 6 x 13 KZ 1 8.8 A3D
14	0000 502 814 11	1		M22 x 1,5 31lang
15	-----	-		
16	-----	-		
17	0000 506 562 00	1		
18	0000 011 230 00	1		
19	0000 039 119 00	0... 1		1000mm
19	0000 054 220 00	0... 1		2000mm

Z07b

High dipstick, oil filter vertical
 Tauchstab hochgezogen, Schmierölfilter vertikal
 Jauge haut, filtre a huile vertical
 Varilla aceite, filtro de aceite vertical
 asta alta, filtro olio verticale

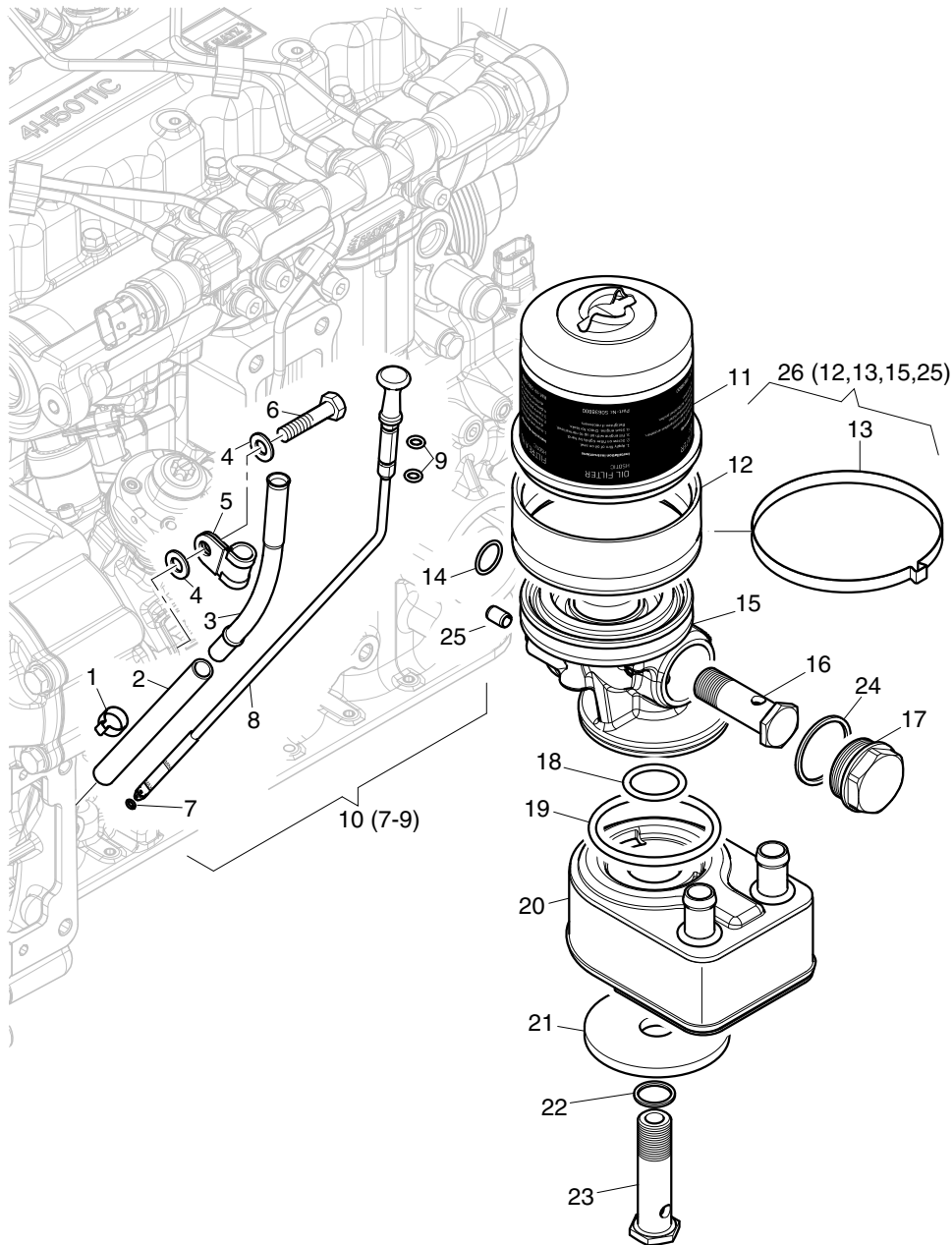

Fig.- No.	HATZ Ident-No.	Qty. Stück	W d / D	Notes Bemerkungen
4H50TIC				
1	0000 505 112 01	1		14,5
2	0000 052 855 00	1		
3	0000 050 535 10	1		
4	0000 501 481 00	2		8,4 DIN 125-St A3C
5	0000 505 898 00	1		
6	0000 501 498 00	1		M 8 x 35 DIN 933 - 8.8 A3C
7	0000 502 025 02	1		3,0 x 1,6
8	-----	-		
9	0000 400 220 00	2		5 x 2
10	0000 020 481 01	1		
11	0000 024 024 00	1		
12	0000 043 168 00	1		
13	0000 506 443 00	1		Ø 99,4 - 102,5
14	0000 500 907 00	1		
15	-----	-		
16	0000 043 170 00	1		
16	0000 500 907 00	1		
17	0000 043 243 00	1		M 35 x 1,5
18	0000 506 492 00	1		
19	0000 506 445 00	1		
20	0000 506 354 10	1		
21	0000 043 172 00	1		
22	0000 500 014 00	1		A 18 x 22 DIN 7603 - Cu
23	0000 043 171 00	1		
24	0000 043 242 00	1		
25	0000 500 849 01	1		8 x 12 DIN 7346 55 Si 7 2Fasen
26	0000 024 234 00	1		

Z14

Flywheel, intermediate housing
 Schwungrad, Anschlußgehäuse
 Volant, bride raccord
 Volante, caja de conexión
 Volano, flangiatura

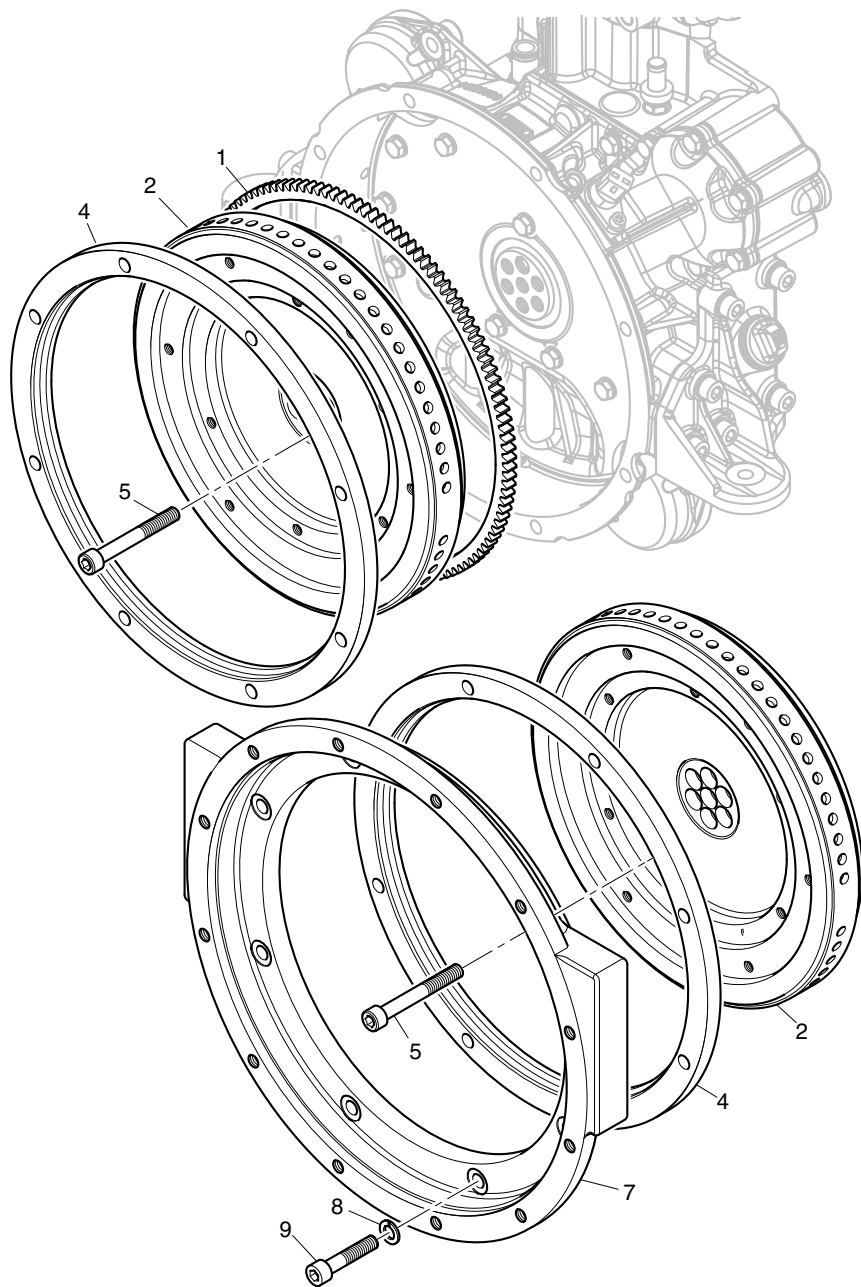

Fig.- No.	HATZ Ident-No.	Qty. Stück	W d / D	Notes Bemerkungen
4H50TIC				
1	0000 040 212 10	1		
2	0000 042 952 10	1		SAE 6,5" & SAE 8"
4	0000 043 234 00	1		SAE 5
5	0000 506 299 00	7		M10 X 1 X 80 DIN912-12.9
7	0000 036 792 00	1		SAE 4
8	0000 500 029 00	8		A 10 DIN 128
9	0000 503 618 00	8		M 10 x 50 DIN 912-8.8A3C

Z16

External bearing
 Aussenlager
 Palier extérieur
 Rodamiento exterior
 Cuscinetto esterno

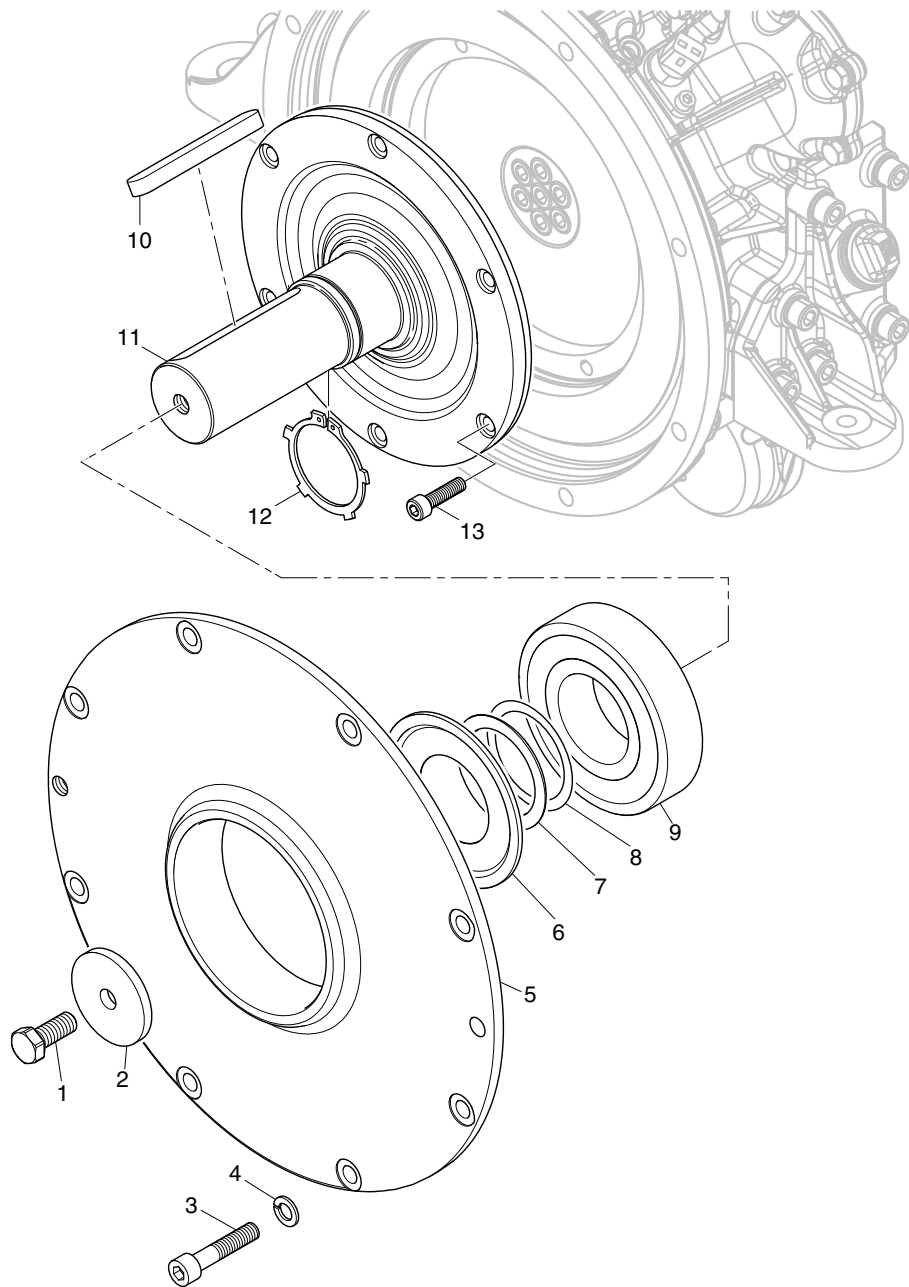

Fig.- No.	HATZ Ident-No.	Qty. Stück	W d / D	Notes Bemerkungen
4H50TIC				
1	0000 500 312 00	1		M 12 x 30 DIN 933-8.8
2	0000 034 802 00	1		12,5 x 58 x 6
3	0000 503 618 00	8		M 10 x 50 DIN 912-8.8A3C
4	0000 501 356 00	8		10 DIN 128 A3C
5	0000 043 241 00	1		
6	0000 502 610 00	1		
7	0000 502 611 00	1		
8	0000 506 016 00	1		55 x 68 x 0,1
9	0000 502 613 00	1		
10	0000 500 626 00	1		A14 x 9 x 100
11	0000 043 239 00	1		Ø 48mm
11	0000 043 240 00	1		Ø 50mm
12	0000 502 612 00	1		AL55 x 2
13	0000 501 279 01	6		M 8 x 40 DIN 912-12.9

Mount. parts hydr. pump
 Anbauteile Hydraulikpumpe
 Pièces mont. -pompe hydr.
 Piezas mont. bomba hidr.
 Particolari per montaggio pompa idraulica

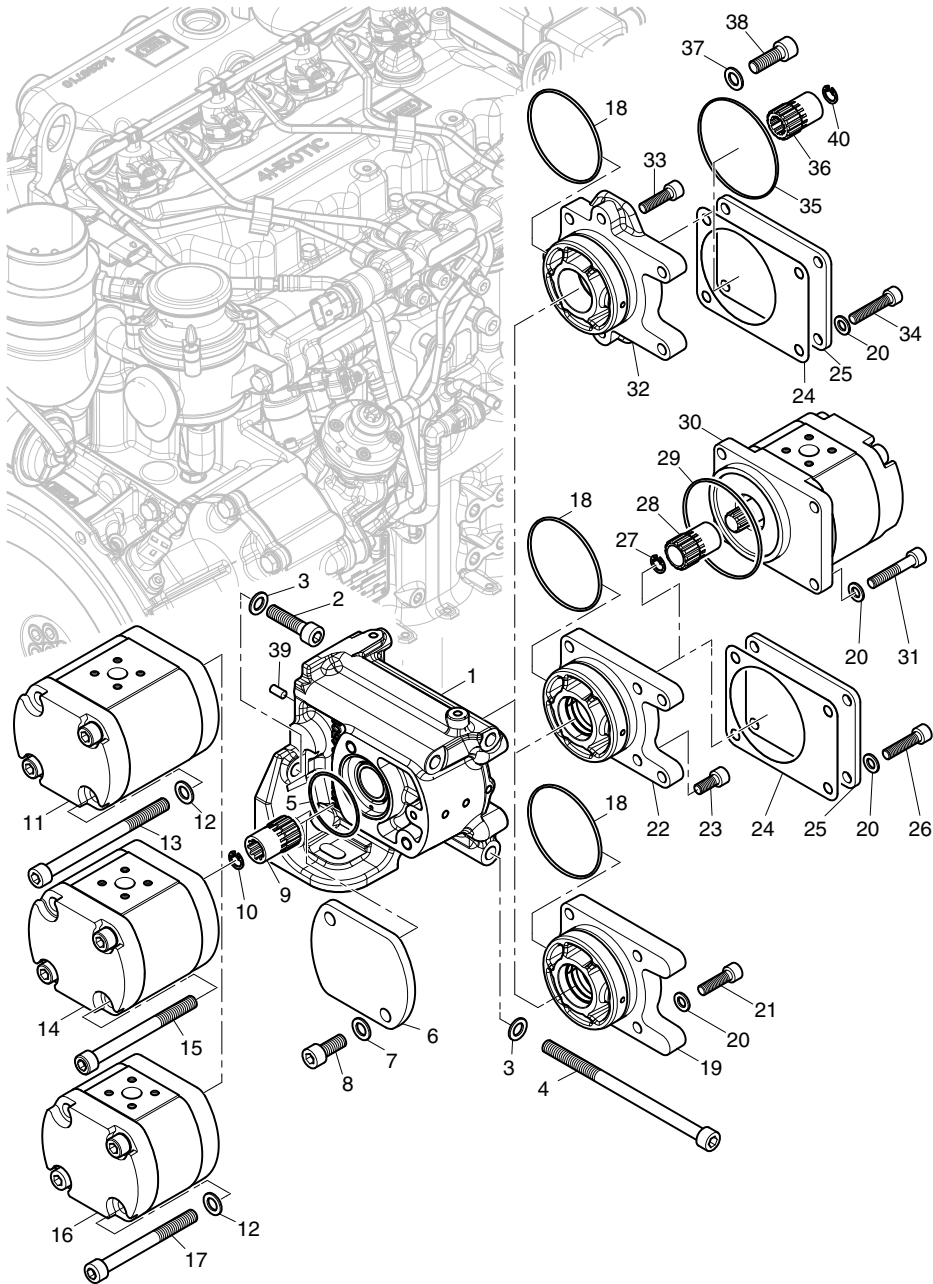

Fig.- No.	HATZ Ident-No.	Qty. Stück	W d / D	Notes Bemerkungen
4H50TIC				
1	0000 024 253 00	1		
2	0000 500 546 00	3		
3	0000 500 170 00	6		M 10 x 40 DIN 912 - 8.8
4	0000 506 358 00	3		10,5 DIN 433 - St A3C
5	0000 503 425 00	1		M 10 X 170 DIN 912-8.8A3B
6	0000 043 055 00	1		48 x 1,7
7	0000 500 170 00	2		10,5 DIN 433 - St A3C
8	0000 502 903 00	2		M 10 x 25 DIN 912-8.8A3C
9	0000 038 434 00	1		
10	0000 500 197 00	1		J 14 x 1 DIN 472
11	0000 506 356 00	1		30cm ³
12	0000 500 170 00	2		10,5 DIN 433 - St A3C
13	0000 506 323 01	2		M 10 X 130 DIN 912-10.9
14	0000 506 365 00	1		22cm ³
15	0000 506 364 00	2		M 10 X 110 DIN 912-10.9
16	0000 506 361 00	1		12cm ³
17	0000 506 189 01	2		M 10 X 100 DIN 912-10.9
18	0000 505 472 02	1		73 x 2
19	0000 024 254 00	1		
20	0000 501 157 00	4		8,4 DIN433-St 140 HV
21	0000 501 759 00	4		M 8 x 30 DIN 912-8.8A3C
22	0000 024 255 00	1		
23	0000 503 663 00	2		M 8 x 20 DIN 912-8.8A3C
24	0000 035 680 00	1		
25	0000 037 616 00	1		
26	0000 501 830 00	4		M 8 x 35 DIN 912-8.8A3C
27	0000 500 197 00	1		J 14 x 1 DIN 472
28	0000 038 434 00	1		
29	0000 506 359 00	1		80 x 2
30	0000 506 363 00	1		12cm ³
31	0000 501 710 00	4		M 8 x 45 DIN 912-8.8A3C
32	0000 024 256 00	1		
33	0000 501 759 00	2		M 8 x 30 DIN 912-8.8A3C
34	0000 501 775 00	4		M 8 x 40 DIN 912-8.8A3C
35	0000 506 371 00	1		82,5 x 2
36	0000 043 076 00	1		
37	0000 500 170 00	2		10,5 DIN 433 - St A3C
38	0000 500 934 00	2		M 10 x 30 DIN 912-8.8A3C
39	0000 506 452 00	2		6 M6X12 DIN6325
40	0000 506 601 00	1		J 13 x 1 DIN 472

Hose system and Radiator at horizontal oilcooler
 Verschlauchung und Wasserkühler bei horizontalem Ölkühler

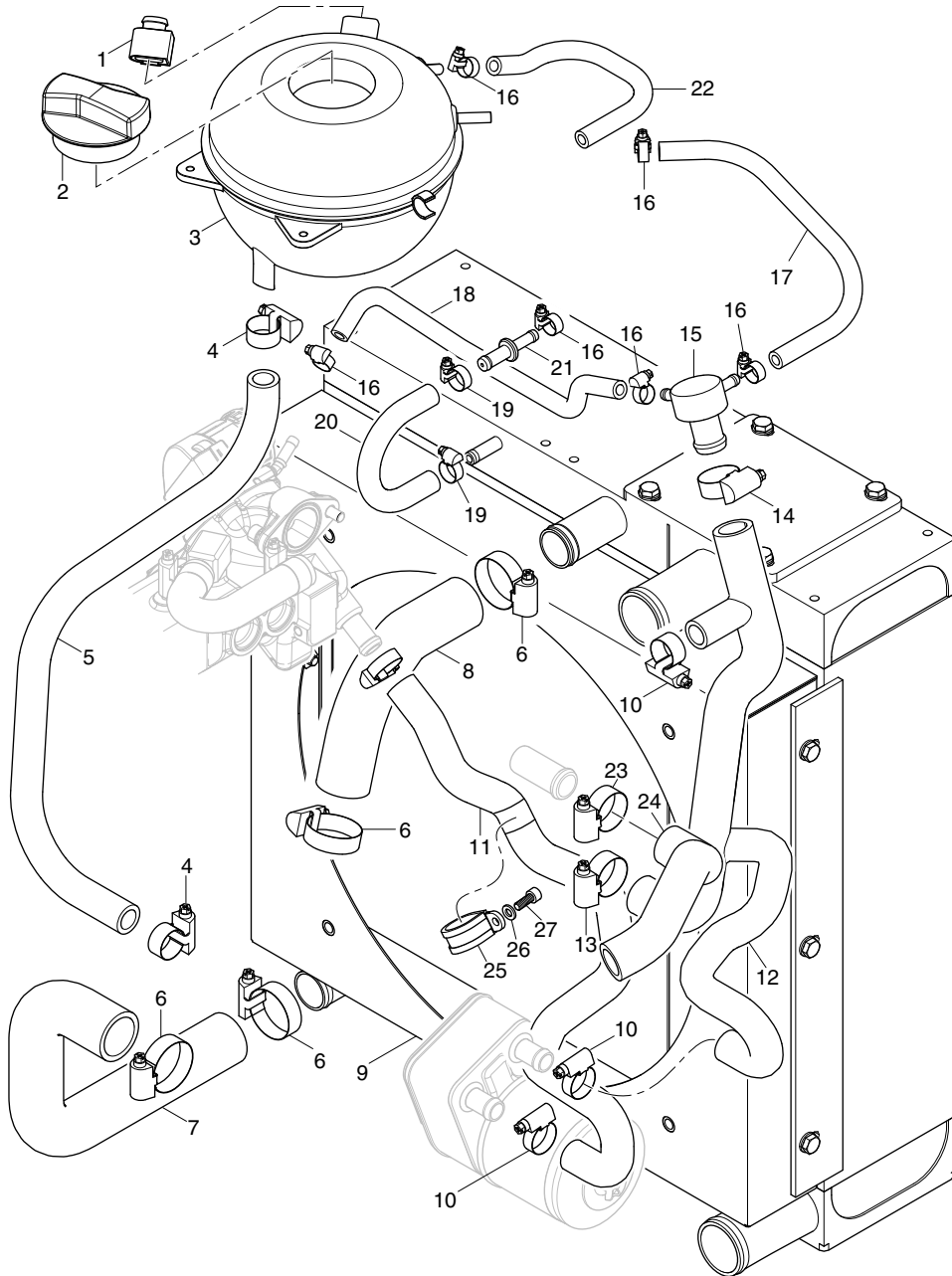

Fig.- No.	HATZ Ident-No.	Qty. Stück	W d / D	Notes Bemerkungen
4H50TIC				
1	0000 506 293 00	1		
2	0000 506 292 00	1		
3	0000 506 291 00	1		
4	0000 504 745 00	2		
5	0000 043 147 00	1		16x4x600 evtl. Meterware anb.
6	0000 505 570 00	4		25-40X12
7	0000 043 080 00	1		
8	0000 043 081 10	1		
9	0000 023 528 10	1		
10	0000 504 756 00	4		12-22x9
11	0000 043 112 00	1		
12	0000 043 130 00	1		
13	0000 506 412 00	1		20-32x13
14	0000 506 520 00	1		16-27x12
15	0000 020 399 00	1		
16	0000 400 261 00	6		10-16
17	0000 043 116 00	1		evtl. Meterware anb.
18	0000 043 100 10	1		evtl. Meterware anb.
19	0000 506 411 00	2		12-18x7,5
20	0000 052 802 00	1		10x17x180
21	0000 043 145 00	1		
22	0000 043 149 00	1		8x3x210 evtl. Meterware anb.
23	0000 506 412 00	0... 1		20-32x13
24	0000 043 082 00	0... 1		22x5
25	0000 506 566 00	1		
26	0000 501 445 00	1		6,4 DIN 125-St A3C
27	0000 501 707 00	1		M 6 x 16 DIN 912-8.8A3C

Hose system and Radiator at vertical oilcooler
 Verschlauchung und Wasserkühler bei vertikalem Ölkühler

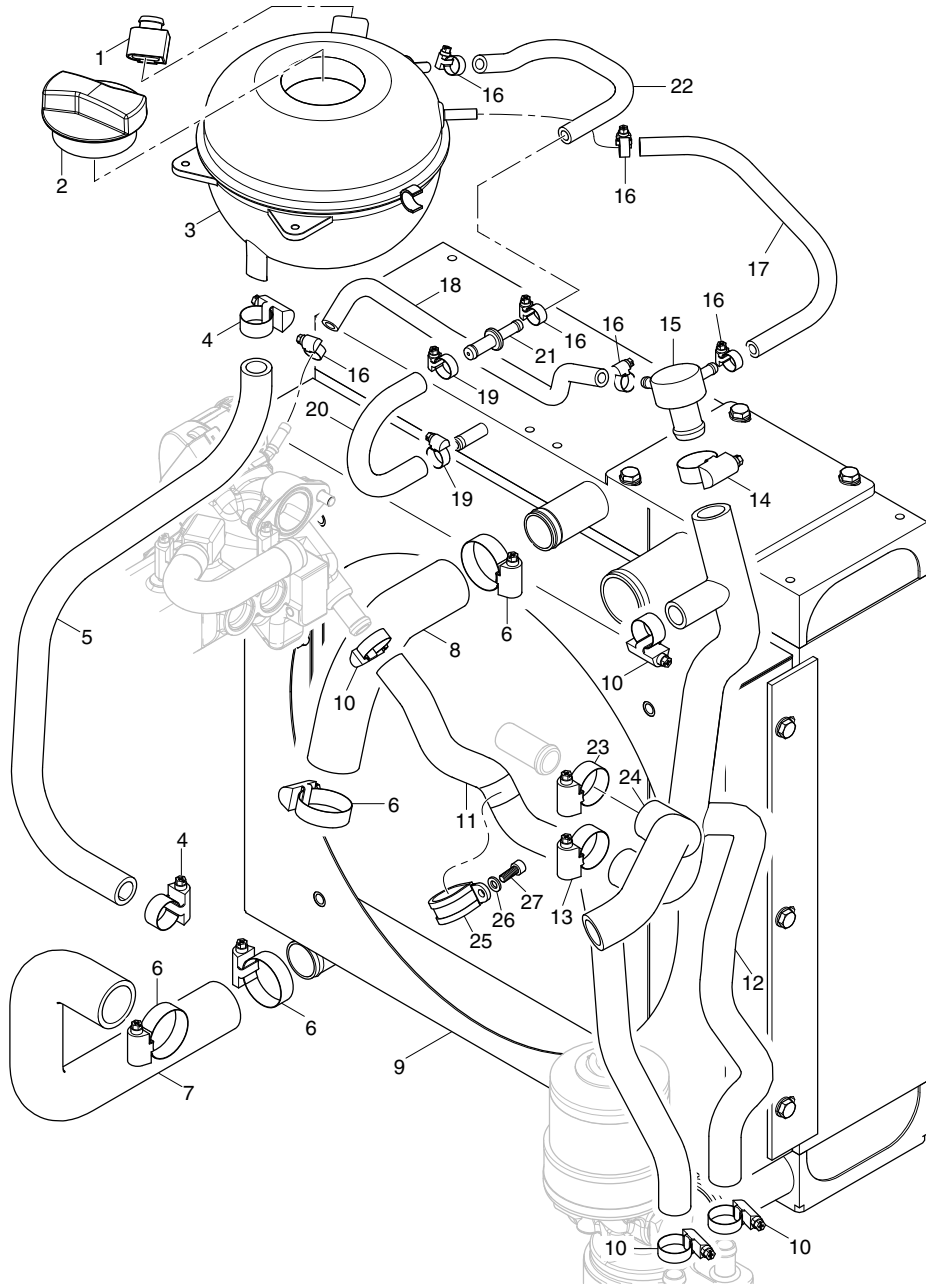

Fig.- No.	HATZ Ident-No.	Qty. Stück	W d / D	Notes Bemerkungen
4H50TIC				
1	0000 506 293 00	1		
2	0000 506 292 00	1		
3	0000 506 291 00	1		
4	0000 504 745 00	2		
5	0000 043 147 00	1		16x4x600 evtl. Meterware anb.
6	0000 505 570 00	4		25-40X12
7	0000 043 080 00	1		
8	0000 043 081 10	1		
9	0000 023 528 10	1		
10	0000 504 756 00	4		12-22x9
11	0000 043 119 00	1		
12	0000 043 131 00	1		
13	0000 506 412 00	1		20-32x13
14	0000 506 520 00	1		16-27x12
15	0000 020 399 00	1		
16	0000 400 261 00	6		10-16
17	0000 043 116 00	1		evtl. Meterware anb.
18	0000 043 100 10	1		evtl. Meterware anb.
19	0000 506 411 00	2		12-18x7,5
20	0000 052 802 00	1		10x17x180
21	0000 043 145 00	1		
22	0000 043 149 00	1		8x3x210 evtl. Meterware anb.
23	0000 506 412 00	0... 1		20-32x13
24	0000 043 082 00	0... 1		22x5
25	0000 506 566 00	1		
26	0000 501 445 00	1		6,4 DIN 125-St A3C
27	0000 501 707 00	1		M 6 x 16 DIN 912-8.8A3C

Z30c, Z08

Waterpump, fan, safety guard
 Wasserpumpe, Lüfter, Schutzgitter
 Pompe a eau, ventilateur, grille protectrice
 Bomba de agua, ventilador, rejilla protectora
 Pompa idraulica, ventilatore, grata di protezione

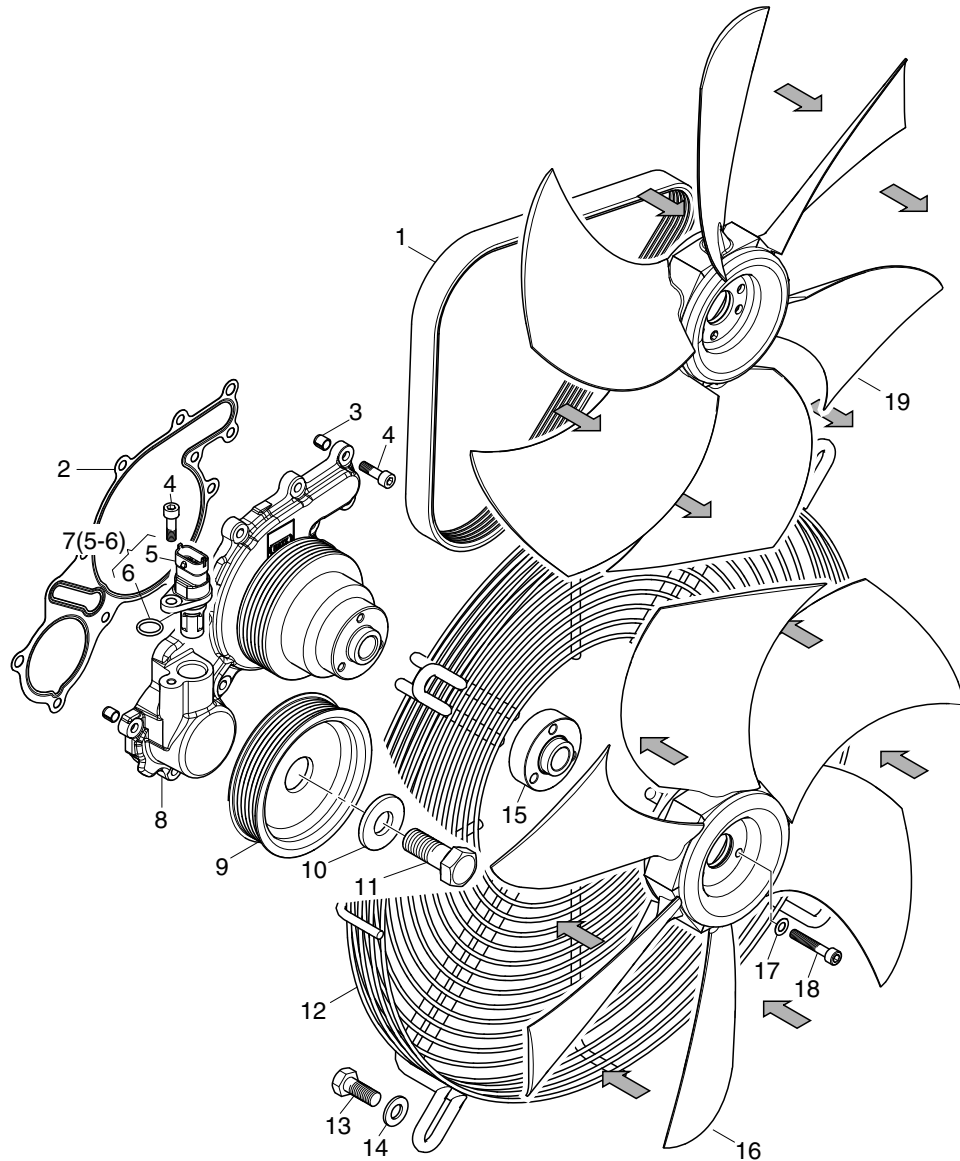

Fig.- No.	HATZ Ident-No.	Qty. Stück	W d / D	Notes Bemerkungen
4H50TIC				
1	0000 506 294 01	1		768mm
2	0000 054 314 00	1		
3	0000 501 400 00	2		8 x 8 DIN 7346 55 Si 7
4	0000 501 706 00	12		M 6 x 20 DIN 912-8.8A3C
5	-----	-		
6	-----	-		
7	0000 506 286 00	1		
8	0000 023 429 00	0... 1		Ø 92mm i=1,116 x N engine
8	0000 024 184 00	0... 1		Ø 77mm i=1,33 x N engine
9	0000 054 301 00	1		Ø 103mm
10	0000 506 289 00	1		Ø16 DIN 6796 - FST
11	0000 506 290 00	1		M16x1,5x40 DIN 961-8.8A3C-LH
12	0000 054 338 00	1		
13	0000 501 364 00	4		M 10 x 25 DIN 933 - 8.8 A3C
14	0000 500 706 00	4		10,5 x 25 x 4 DIN 7349 A3C
15	0000 054 273 00	1		
16	0000 506 287 00	0... 1		Ø410mm / 6-6 / 30°
17	0000 500 812 00	3		A 6 DIN 137 - A3C
18	0000 503 749 00	3		M 6 x 35 DIN 912-8.8A3C
19	0000 506 580 00	0... 1		Ø410mm / 6-6 / 30°

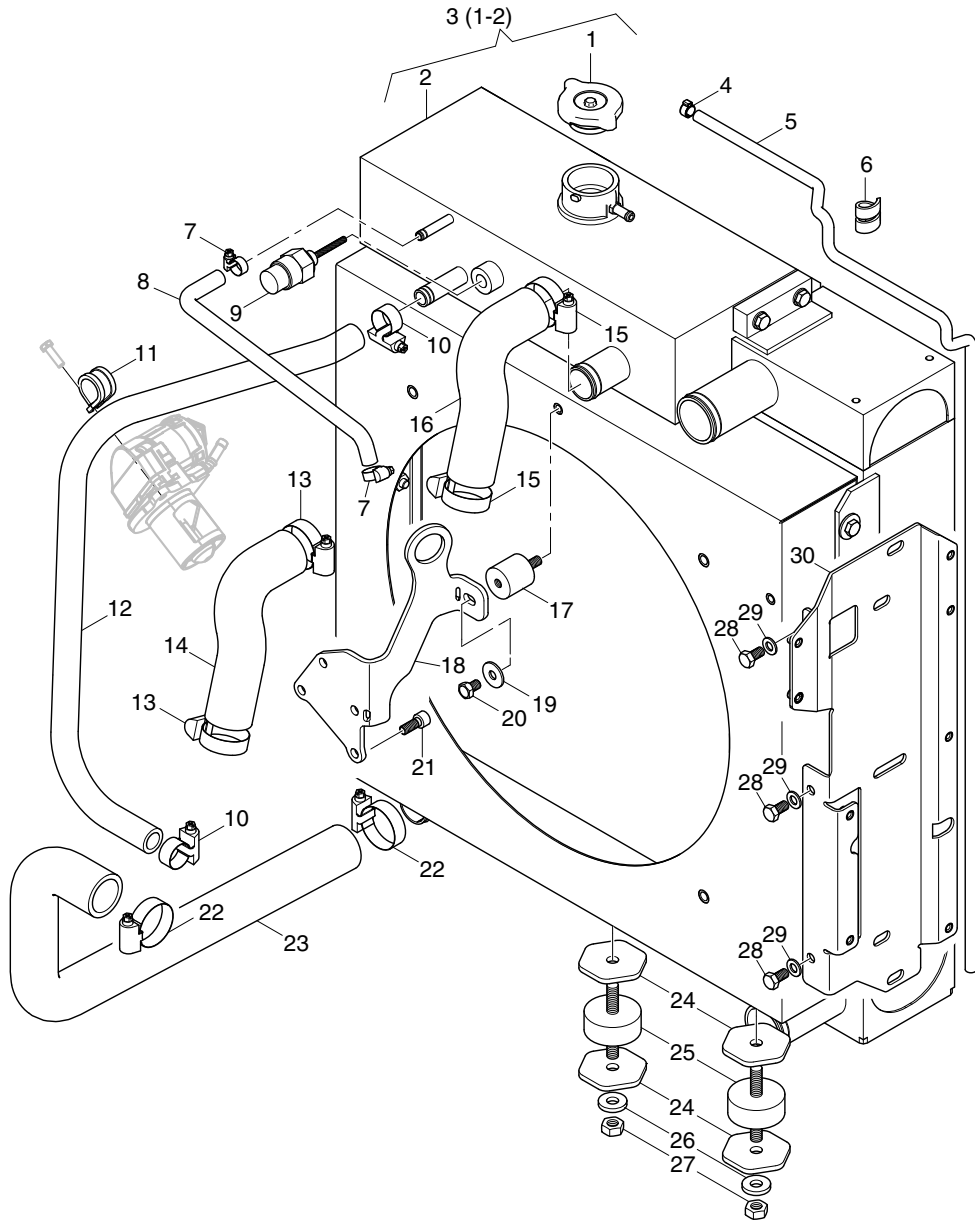
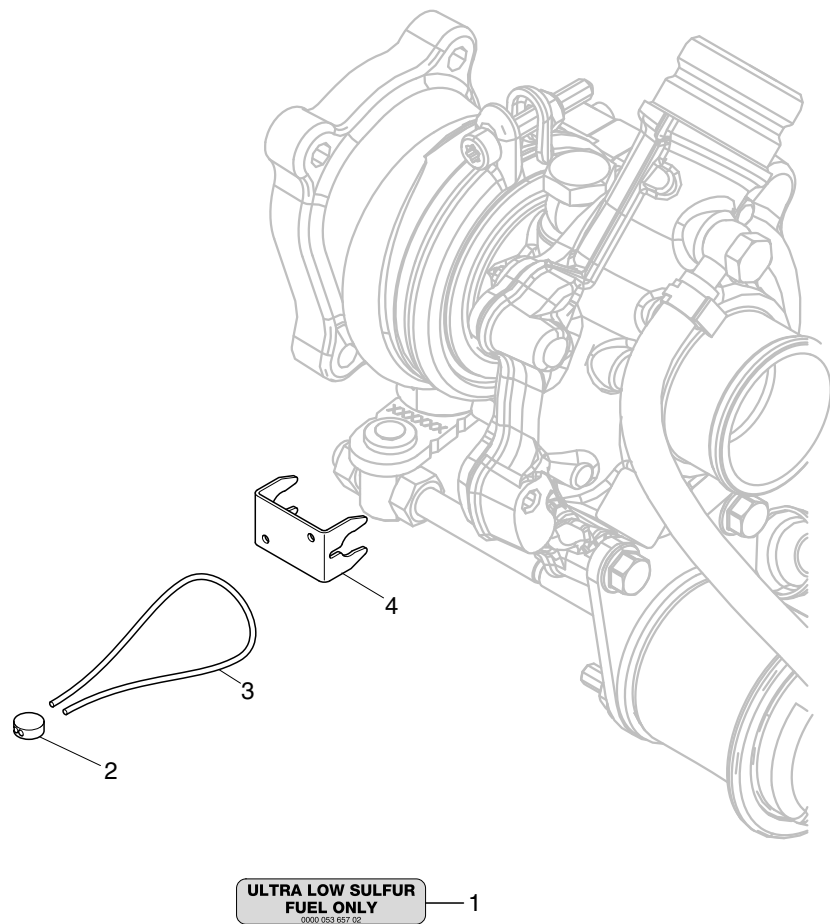

Fig.- No.	HATZ Ident-No.	Qty. Stück	W d / D	Notes Bemerkungen
4H50TIC				
1	-----	1		Niederhofer fragt Lieferanten
2	-----	-		
3	0000 024 062 00	1		
4	0000 505 709 00	1	12,8	
5	0000 054 830 00	1		
6	0000 050 239 00	1		
7	0000 400 261 00	2	10-16	
8	0000 043 249 00	1		
9	0000 506 559 00	1		
10	0000 504 756 00	2	12-22x9	
11	0000 501 903 10	1		
12	0000 043 246 00	1		
13	0000 505 570 00	2	25-40X12	
14	0000 043 249 00	1		
15	0000 505 570 00	2	25-40X12	
16	0000 043 248 00	1		
17	0000 506 084 00	1		
18	0000 054 829 00	1		
19	0000 500 629 00	1	8,4 DIN 9021 St A3C	
20	0000 500 962 00	1	M 8 x 12 DIN 933 - 8.8 A3C	
21	0000 503 663 00	4	M 8 x 20 DIN 912-8.8A3C	
22	0000 505 570 00	2	25-40X12	
23	0000 043 247 00	1		
24	0000 039 934 00	4	10,5 x 55 x 5	
25	0000 503 460 00	2		
26	0000 500 706 00	2	10,5 x 25 x 4 DIN 7349 A3C	
27	0000 501 458 00	2	M 10 DIN 934-8 A3C	
28	0000 500 985 00	3	M 8 x 16 DIN 933-8.8 A3C	
29	0000 501 481 00	3	8,4 DIN 125-St A3C	
30	0000 024 063 00	1		

Z90

Spec. equipment EPA
 Motorausrüstung EPA
 Equipm. spec. EPA
 Equipo espec. EPA
 Kit trasformazione EPA

Fig.- No.	HATZ Ident-No.	Qty. Stück	W d / D	Notes Bemerkungen
4H50TIC				
1	0000 053 657 02	1		
2	0000 400 214 00	1		8 mm ø
3	0000 400 215 00	1		0,5 / 0,3 x 200
4	0000 043 245 00	1		





HATZ service network

A	Austria	2320 Schwechat - Rannersdorf	Josef Hofmann GmbH.	+43 - 1 - 7 07 06 08
A	Austria	4600 Wels	Motor Center Austria GmbH	+43 - 7242 - 4 71 61-0
A	Austria	5020 Salzburg	Ing. R. Schneider	+43 - 662 - 87 23 54
A	Austria	6065 Thaur	Romed Müssigang	+43 - 5223 - 49 28 34
A	Austria	6830 Rankweil	Ländletechnik Schäfer GmbH	+43 - 5522 - 4 50 60
A	Austria	8073 Feldkirchen	Langbauer - Motoren e.U.	+43 - 316 - 71 15 95
A	Austria	9170 Ferlach	Johann Koslitsch	+43 - 4227 - 59 33
AN	Angola	94099 Ruhstorf	HATZ Ruhstorf	+43 8531 319 0
AUS	Australia	2164 Smithfield NSW	HATZ Australia Pty. Ltd.	+61 - 2 - 8788 7999
AZ		1029 BAKU	AS TEXNIKA LLC	+99412 418 0106 562
B	Belgium	3090 OVERIJSE	BIA GROUP NV/SA	+32(0)2 689 28 11
BF	Burkina Faso	Ouagadougou 01	Impex Afrique	+226 - 50 43 37 37
BG	Bulgaria	1000 Sofia	ENERGIA-MARVAKOV GMBH	+359 - 29 62 14 95
BHT	Bhutan	Gongkhar Bumthang	Jigme Norbu Enterprise	+975 - 3 - 63 11 81 or 63 11 70
BR	Brazil	09220-790 SANTO ANDRE - SAO PAULO	DAIFORCE COM DE MAQ. E MOTORES	
LTDA		+55 11 4461 4979		
BRN	Bahrain	646 Nuwaidrat	Gulf Equipment & Technology (G.E.T.)	+973 - 170 00 08
BY	Belarus	223021 Minsk region	PC LTD, FOMAR	+375 - 17 - 507 68 20
CAM	Cameroon	DOUALA	EMEI DIESEL Sarl	00237 33 42 87 51
CDN	Canada	WI 53186-1153 Waukesha	HATZ Diesel of America, Inc.	+1 - 262 - 5 44 02 54
CH	Switzerland	8852 Altendorf	Motorenfabrik HATZ AG	+41 - 55 - 4 51 75 30
CI	Côte d' Ivoire	1691 ABIDJAN 11	PRESTIGE - AUTO	+225 21756555
CN	China	Xiamen	Motorenfabrik Hatz GmbH. & Co. KG.	+86 - 592 - 520 45 -28/-38/-78
CO	Columbia	Medellin	Eduardoño S.A.	+ 57 - 4 444 5888
CR	Costa Rica	94099 Ruhstorf	Motorenfabrik Hatz GMBH & CO. KG	+49 (0)8531 319 373
CY	Cyprus	3724 Limassol	L.NEMITSAS LTD	+357 - 25 - 56 92 25
CZ	Czech Republic	37001 Ceske Budejovice	David Servis spol. s.r.o.	+420 - 38 - 7 31 22 69
D	Germany	02730 Ebersbach	Peter Hirche	+49 - (0)3586 - 36 23 79
D	Germany	03130 Spremberg	Lischke Motortechnik	+49 - (0)3563 - 60 50 40
D	Germany	04509 Wiedemar	SERVICEZENTRALE	+49 - (0)34207 - 7 44 0
D	Germany	07957 Langerwetzendorf	LAREMO GmbH	+49 - (0)3 66 25 / 5 52 40
D	Germany	09669 Frankenberg	Huebner u. Kluge GmbH	+49 - (0)37206 - 22 17
D	Germany	12057 Berlin	Fritz Bugel GmbH	+49 - (0)30 - 6 84 25 45
D	Germany	15345 Altlandsberg	KFZ-Instandsetzung Hase	+49 - (0)33438 - 6 04 16
D	Germany	15831 Groß-Kienitz	Wilhelm Schmidt GmbH	+49 - (0)3 37 08 - 54 10
D	Germany	17235 Neustrelitz	Autek-Truck - Technik & Service GmbH	+49 - (0)3981 - 4 49 90
D	Germany	18055 Rostock	Mechanische Werkstatt	+49 - (0)381 - 69 08 20
D	Germany	18442 GROß-LÜDERSHAGEN	MOTOR-SPEZI	03831-444393
D	Germany	19348 Düprow	Bernd Jüchert	+49 - (0)3876 - 78 89 31
D	Germany	21107 Hamburg (Wilhelmsburg)	SERVICEZENTRALE	+49 - (0)40 - 7 56 05 70
D	Germany	23556 Lübeck	Kindt-Motoren	+49 - (0)451 - 8 13 06 80
D	Germany	24145 Kiel - Wellsee	Wulf Johannsen KG GmbH & Co.	+49 - (0)431 - 58 795 33
D	Germany	26215 NEUENKRUGE	MOTORENINSTANDSETZUNG OLDENBURG GMBH	+49 - (0)441 -
7 20 21/22				
D	Germany	28199 Bremen	Reinhold Linnenbrügger GmbH	+49 - (0)421 - 50 40 48 / 50 40 49
D	Germany	31275 Lehrte	GM-Motoreninstandsetzung	+49 - (0)5132 - 27 22

HATZ service network



D	Germany	32756 Detmold	Wilhelm Plass	+49 - (0)5231 - 2 32 09
D	Germany	33611 Bielefeld	Faust & Noel e.K.	+49 - (0)521 - 6 18 83
D	Germany	36433 Moorgrund / OT Gumpelstadt	Autohaus Kallenbach	+49 - (0)3695 - 8 42 38
D	Germany	37081 Göttingen-Grone	Gerhard Wienstroth GmbH & Co. KG	+49 - (0)551 - 69 31 10
D	Germany	39124 Magdeburg	Motoreninstandsetzung GmbH	+49 - (0)391 - 28 92 11 0
D	Germany	44143 Dortmund-Wambel	Dressendorfer GmbH & Co. KG	+ 49 (231) 565563(0)-11
D	Germany	47198 Duisburg	ASS	02841/1733117
D	Germany	48282 Emsdetten	Herbert Schwarte GmbH	+49 - (0)2572 - 50 02
D	Germany	48653 Coesfeld	Loick Motoren Technik GmbH. & Co. KG.	+49 - (0)2541 - 7 00 44
D	Germany	49716 Meppen/Ems	KEM -KLOSKA ENERGIE- UND MOTORENTECHNIK	+49 5931 9844
51				
D	Germany	50859 Köln	Peter Müller GmbH	+49 - (0)2234 - 7 91 69
D	Germany	52477 Alsdorf - Mariadorf	B. Hamacher GmbH	+49 - (0)2404 - 9 85 60
D	Germany	52525 Heinsberg	Motoren Ritterbecks	02452-3126
D	Germany	54292 Trier	motormobile	+49 - (0)651 - 43 68 60
D	Germany	56323 Waldesch	Seibert & Münch	+49 - (0)2628 - 29 01
D	Germany	57368 Lennestadt	Motoreninstandsetzung	+49 - (0)2725 - 2 47
D	Germany	59069 Hamm-Rhynern	Friedel Dicke GmbH	+49 - (0)2385 - 7 08 06-0
D	Germany	59609 Anröchte	Friedrich Dicke GmbH & Co.KG	+49 - (0)2947 - 979863
D	Germany	64293 Darmstadt	SERVICEZENTRALE	+49 (0)6151 - 39 7 49 0
D	Germany	67661 Kaiserslautern (Siegelbach)	Emrich GmbH	+49 - (0)6301 - 80 82, 80 83
D	Germany	69214 Eppelheim	Eberle Hald Handel u. Dienstleistungen	+49 (0) 6221 7558 39 - 0
D	Germany	70188 Stuttgart	Eberle Hald Handel u. Dienstleistungen	+49 (0) 711 480 24 - 0
D	Germany	72555 Metzingen	Eberle Hald Handel u. Dienstleistungen	+49 - (0)7123 - 92 31 0
D	Germany	73492 Rainau-Goldshoefe	Eberle Hald Handel u. Dienstleistungen	+49 (0)7361 9718 02
D	Germany	76139 Karlsruhe	Ehlgötz	+49 - (0)721 - 6 23 54-0
D	Germany	76571 Gaggenau	SKS-Motoren GmbH	+49 - (0)7225 - 96 08 23
D	Germany	78652 Deisslingen	Eberle Hald Handel u. Dienstleistungen	+49 (0) 7425 3386 - 0
D	Germany	79211 Denzlingen	Karl Hoch GmbH	+49 - (0)7666 - 88 24-0
D	Germany	79331 Teningen - Nimbürg	Eberle Hald Handel u. Dienstleistungen	+49 (0)7663 9309 - 0
D	Germany	81477 München	Stefan Lutzenberger	+49 - (0)89 - 78 20 39
D	Germany	83483 Bischofswiesen	Friedrich Dicke GmbH & Co. KG	+49 - (0)8652 - 6 43 06
D	Germany	84381 EMMERSDORF	BAUMASCHINEN & GARTENGERÄTE SAUER	+49 - (0)8564 96 35 603
D	Germany	88074 Meckenbeuren	Eberle Hald Handel u. Dienstleistungen	+49 (0) 7542 9410 - 0
D	Germany	90449 Nürnberg	Guth & Eberle GmbH	+49 - (0)911 - 6 88 79 53
D	Germany	94099 Ruhstorf	Motorenfabrik Hatz GmbH & Co. KG	+49 - (0)8531 - 31 90
D	Germany	97904 Dorfprozelten	MSG Mainschiffahrts-	+49 - (0)9392 - 93 41-0
DK	Denmark	2640 HEDEHUSENE (TAASTRUP KOMUNE)	Erenfred Pedersen A/S	+45 - 43 71 01
66				
DK	Denmark	6000 Kolding	Erenfred Pedersen A/S	+45 - 76 33 60 60
DK	Denmark	9000 Aalborg	Erenfred Pedersen A/S	+45 - 98 13 77 22
DOM	Dominican Rep.	Santo Domingo	La Antillana Comercial, S.A.	+1 - 809 - 5 65 31 51
DZ	Algeria	Alger	Dieselec S.A.R.L.	+ 213 23 77 65 68/69
E	Spain	01013 Vitoria	Talleres Solaf, S.A.	+34 - 945 - 260781
E	Spain	07714 Mahón	Parot, S.A.	+34 - 971 - 360623
E	Spain	08038 Barcelona	Comercial Aim, S.L.	+34 - 93 - 3393250



HATZ service network

E	Spain	15008 A Coruña	Talleres Hércules	+34 - 981 - 261650 / 252935
E	Spain	17469 Fortià (Girona)	Mauricio Xatarí Tell	+34 - 972 - 534088
E	Spain	18080 Granada	Comercial Peña Torres	+34 - 958 - 816600
E	Spain	18200 Maracena	Talleres Soriano	+34 - 958 - 410689
E	Spain	23009 Jaén	Comercial Peña Torres, S.A.	+34 - 953 - 28 05 77
E	Spain	28942 Fuenlabrada (Madrid)	Austral Reparaciones y Servicios, S.L.	91 691 80 29
E	Spain	29004 Málaga	Comercial Peña Torres	+34 - 952 - 17 70 72
E	Spain	30500 Molina de Segura	Campos López	+34 - 968 - 386248
E	Spain	31192 Mutilva Alta	Maquinaria y Servicios ECA	+34 - 948 - 24 10 17
E	Spain	33211 Gijón	Maprinsa, S.A.	+34 - 985 - 167772
E	Spain	35008 El Sebadal	Fuendor	+34 - 928 - 46 53 06
E	Spain	38320 Taco	Fuendor (Repuestos)	+34 - 922 - 65 54 50
E	Spain	38350 Tacoronte	Lujor Maquinaria S.L.	+34 - 922 - 10 10 41
E	Spain	41007 Sevilla	Repuestos Correa	+34 - 954 361866
E	Spain	43206 Reus (Tarragona)	Tractomecanic Maquinaria S.L.	+34 - 977 - 314923
E	Spain	45600 Talavera de la Reina	Talleres Mendez	925 80 13 97
E	Spain	46469 Beniparell (Valencia)	Talleres Rimi	+34 - 96 - 1 21 70 91
E	Spain	47193 La Cisterniga	Zafara	+34 - 983 - 476851 / 225620
E	Spain	50016 Zaragoza	Loma e Hijos, S.L.	+34 - 976 - 575177 / 570809
E	Spain	50171 La Puebla de Alfindén (Zaragoza)	Motores HATZ Espana S.L.U.	+34 - 976 - 10 81 28
EAK	Kenya	00100 Nairobi	First Machineries Ltd.	+254 - 20 - 55 77 86
EC	Ecuador	Guayaquil	Compañía Comercial	+593 - 4 -256 05 02
ES	El Salvador	San Salvador	TEMSA	+503 - 2239 8600
ET	Egypt	11331 Cairo	Market Leaders	+20 - 22 - 4 53 07 63, 4 53 09 17
ETH	Ethiopia	94099 RUHSTORF	MOTORENFABRIK HATZ GMBH & CO.KG	+49 8531 319 425
EW	Estonia	11612 Tallinn	Estmotor Oü	+372 - 6 52 65 95
F	France	10350 MARIGNY LE CHATEL	GARAGE MATHIEU V.I.	+33 3 - 25 39 24 01
F	France	10350 MARIGNY LE CHATEL	GARAGE MATHIEU V.I.	+33 3 25 39 24 01
F	France	10350 MARIGNY LE CHATEL	GARAGE MATHIEU V.I.	+33 3-25-39-24-01
F	France	13852 AIX-EN-PROVENCE	I.M.F.	+33 4 - 42 90 30 65
F	France	14123 IFS	BOUVET S.A.S	+33 - 2 - 31 52 01 47
F	France	14123 IFS	BOUVET SARL	+33 2 - 31 52 01 47
F	France	19100 Brive	Saint-Germain Rectif & Pradeau Moteurs	+33 - 5 - 55 86 91 91
F	France	19100 BRIVE LA GAILLARDE	SGR MAINTENANCE	+33 5 - 55 86 91 91
F	France	21560 ARC SUR TILLE	Garage REMILLET	+33 3 - 80 37 24 52
F	France	25410 Saint-Vit	DEPANNT'P	+33 3 - 81 87 61 10
F	France	27002 EVREUX Cedex	DEMOLIN	+33 2 - 32 39 07 22
F	France	31300 TOULOUSE	MIDI-DIESEL	+33 - 5 - 61 42 80 11
F	France	31300 TOULOUSE	MIDI-DIESEL	+33 5 - 61 42 80 11
F	France	33704 MERIGNAC	LAPORTE	+33 - 5 - 56 34 20 26
F	France	33704 MERIGNAC	LAPORTE	+33 5 - 56 34 20 26
F	France	34671 BAILLARGUES Cedex 01	L.M.S. (Languedoc Matériel Service)	+33 4 - 67 91 29 39
F	France	37170 CHAMBRAY-LES-TOURS	Perron & Gay	+33 - 2 - 47 28 94 94
F	France	37170 CHAMBRAY-LES-TOURS	Perron & Gay	+33 2 - 47 28 94 94
F	France	37170 CHAMBRAY-LES-TOURS	Perron & Gay	02-47-28-94-94
F	France	54710 FLEVILLE DEVANT NANCY	M.T.E. Services	+33 - 3 - 83 25 75 00

HATZ service network



F	France	56402 AURAY Cedex	PENOUEST	+33 - 2 - 97 24 16 59
F	France	59167 LALLAING	COMOTEQ	+33 - 3 - 27 99 35 23
F	France	67300 Schiltigheim	ALSIA SA	+33 - 3 - 88 33 05 95
F	France	69684 Chassieu Cedex	HATZ-France	+33 - 4 - 78 90 73 25
F	France	76800 SAINTETIENNE DU ROUVRAY	MORISSE-NAYRAT MOTORS	02-32-95-91-63
F	France	78610 LE PERRY-EN-YVELINES	SUDMAT INTERNATIONAL	+33 - 1 - 34 57 85 00
F	France	78703 CONFLANS-STE-HONORINE	DIESEL MARINE	+33 - 1 - 39 72 68 83
F	France	94290 VILLENEUVE LE ROI	S.F.2.A	+33 - 1 - 49 61 30 90
FIN	Finland	01390 Vantaa	Finmotor Oy	+358 - 9 - 8 70 09 70
FJI	Fiji	2164 Smithfield NSW	HATZ Australia Pty. Ltd.	+61 - 2 - 8788 7999
G	Gabon	Libreville	MIAG	+241 - 76 00 31, 72 17 27
GB	Great Britain	BL4 OLS Bolton	Seddons Plant	+44 - 1204 - 85 46 00
GB	Great Britain	BS20 7XE Bristol	Rollo UK (Aktion Automotive)	+44 1275 377800
GB	Great Britain	CF24 5EL Cardiff	CPS (European) Ltd.	+44 2920 453194
GB	Great Britain	CM9 5FA Essex	Taylor Construction Plant Ltd	+44 - 1621 - 85 07 77
GB	Great Britain	CV21 1PB Warkwickshire	BrownPower Eng Ltd	+44 - 1788 - 57 75 75
GB	Great Britain	FK16 6AU Perthshire	Young Plant & Equipment	+44 - 1786 - 84 15 98
GB	Great Britain	GL17 0JA Gloucestershire	Titan Industrial Ltd	+44 - 1452 - 83 18 21
GB	Great Britain	KT10 9AJ Surrey	A&P Services (Surrey) Ltd	+44 1372 468315
GB	Great Britain	LE10 3BP Hinckley, Leics.	HATZ Great Britain Ltd.	+44 - 1455 - 62 21 01
GB	Great Britain	LN1 2LR Lincoln	CG Plant Sales	+44 - 1522 - 70 40 14
GB	Great Britain	LS12 6EP Leeds	W.G. Search Ltd	+44 - 1132 - 79 79 90
GB	Great Britain	LS12 JAJ Leeds	Chippindale Plant Ltd	+44 - 113 - 2 63 23 44
GB	Great Britain	LU5 6HF Dunstable	Southern Plant Ltd.	+44 845 304 0001
GB	Great Britain	ME20 6SE Kent	Leach Lewis Plant Ltd.	+44 1622 718118
GB	Great Britain	NE4 7AX Newcastle	John Nixon Ltd.	+44 - 191 - 2 26 06 66
GB	Great Britain	NN11 8QJ Northants	Bryco Group Ltd.	+44 - 1327 - 87 61 66
GB	Great Britain	PL12 6LX Cornwall	AB Services Ltd.	+44 - 1752 - 84 88 20
GB	Great Britain	PO13 0FJ Hampshire	Meetens Industrial Engines	+44 845 6340297
GB	Great Britain	RH19 2Hu West Sussex	Hydraulic Plant Services Ltd.	+44 1343 327300
GB	Great Britain	SN8 2RN Wiltshire	T.H. White	+44 - 1672 - 51 23 28
GB	Great Britain	ST4 3NX Stoke-on-Trent	Seddons Plant	+44 - 1782 - 59 34 44
GB	Great Britain	TO14 9AE Devon	Sleeman & Hawken Ltd.	+44 1626 778266
GB	Great Britain	TS18 2PF Stockton	John Nixon Ltd.	+44 - 1642 - 67 26 94
GCA	Guatemala	Guatemala, Ciudad	Técnico Mercantil S.A.	+ 502 - 2331 4193
GH	Ghana	Accra - North	Agria Machinery	+233 302 222 169
GN	Guinea	Conakry	IDRISSA DIOP	+224 30 47 80 80
GR	Greece	11853 Athens	MAVROGIANNAKIS S.A	+30 210 3461762
GUA	Guadeloupe	97176 Abymes Cedex	Assistance 97 Guadeloupe	+590 - 590 47 09 90
GUY	Guyana	94099 Ruhstorf	Motorenfabrik Hatz GMBH & CO. KG	+49 (0)8531 319 373
H	Hungary	1165 Budapest	Benaco	+36 - 1 - 4 07 37 34
HK	Hong Kong	Xiamen	Motorenfabrik Hatz GmbH. & Co. KG.	+86 - 592 - 520 45 -28/-38/-78
HN	Honduras	Tegucigalpa, D.C.	Corporación Comercial, S.A. de C.V.	+ 504 - 222 0576
HR	Croatia	10000 Zagreb Hrvatska	Diesel Motori d.o.o.	+385 - 1 - 3 46 35 18, 3 46 26 69
I	Italy	00133 Roma	Eros Antonelli S.N.C.	+39 - 06 - 72 65 02 60
I	Italy	04014 Borgo Vodice (LT)	Dorati Luciano	+39 - 0773 - 85 01 09

I	Italy	05100 Terni	Lamperini Services	+39 - 0744 - 30 62 10
I	Italy	06061 Castiglione del Lago	Della Giovampaola Danilo	+39 - 075 - 96 52 433
I	Italy	09034 Elmas CA	De Murtas Antonio & C. S.A.S.	+39 - 070 - 21 61 06
I	Italy	10138 Torino	Centro Ricambio	+39 - 011 - 4 55 11 81/ 4 55 12 11
I	Italy	12030 Faule (Cn)	Multidiesel di Barge Ilario	+39 - 338 - 7 19 94 09
I	Italy	14056 Boglietto di Costigliole d'Asti AT	Barbero Andrea	+39 - 0141 - 96 82 93
I	Italy	16100 Genova	Bruzzone Enzo	+39 - 010 - 3 73 93 96
I	Italy	20068 Peschiera Borromeo (MI)	C.S.D. Centro Servizi Diesel S.R.L.	+39 - 02 - 55 303 000
I	Italy	21040 Origgio (VA)	C.M.R. s.n.c. di Bianchi Roberto & C.	+39 - 02 - 96 73 20 62
I	Italy	22046 Erba CO	Miotto Luciano	+39 - 031 - 64 16 73
I	Italy	24050 Orio al Serio BG	Marconi & Caldara	+39 - 035 - 31 25 76 / 077 04 35
I	Italy	25021 Bagnolo Mella (Bs)	Officina Meccanica	+39 - 030 - 68 21 441
I	Italy	29017 Fiorenzuola d'Arda PC	Arduini Luigi di Arduini Armando	+39 - 0523 - 98 26 39
I	Italy	31057 Silea (Tv)	Trattoricambi sas	+39 - 0422 - 36 12 31
I	Italy	33010 Felleto Umberto Tavagnacco Ud.	Ezio Fiorin Eredi di Alberto Fiorin & C.	+39 - 0432 - 57 30 76
I	Italy	33078 San Vito al Tagliamento (PN)	Officina Venaruzzo Antonio	+39 - 0434 - 87 63 77
I	Italy	34015 Muggia TS	Centro Ricambio	+39 - 040 - 23 17 15
I	Italy	35030 Vo	Giuseppe Marcolongo	+39 - 049 - 9 94 06 76
I	Italy	36060 Romano d'ezzelino (VI)	Parolin Enzo	+39 - 0424 - 3 09 75
I	Italy	38010 S. Michele all'Adige TN	Campese S.N.C.	+39 - 0461 - 65 01 69
I	Italy	39100 Bolzano	Officina D'Ambrosio	+39 - 0471 - 20 42 00
I	Italy	40060 Trebbio Di Reno (BO)	Venturoli Lauro	+39 - 051 - 70 02 41
I	Italy	41030 BOMPORTO	HATZ ITALIA S.R.L. UNIPERSONALE	+39 - 059 - 25 41 29
I	Italy	41126 Modena (MO)	Centro Ricambi	+39 - 059 - 82 62 14
I	Italy	43100 Parma	Arduini Franco e Figlio S.N.C.	+39 - 0521 - 48 75 66
I	Italy	44043 Marzabotto BO	Lolli F.C.	+39 - 051 - 93 24 41
I	Italy	47023 Cesena (FO)	Domeniconi Egisto Romano & C. S.N.C.	+39 - 0547 - 32 55 13
I	Italy	50053 Empoli (FI)	O.R.M.A. di Niccolai Dino e	+39 - 0571 - 8 03 04
I	Italy	50142 Firenze (FI)	Centro Ricambi	+39 - 055 - 7 32 74 43
I	Italy	60035 Jesi AN	Cercaci Officina Meccanica	+39 - 0731 - 20 50 46
I	Italy	66020 Sambuceto (CH)	CO. GAL. CO. S.R.L.	+39 - 085 - 44 600 55
I	Italy	70123 Bari	Morettauto S.R.L.	+39 - 080 - 50 585 60
I	Italy	70123 Bari	Rettifiche de Palma	+39 - 080 - 5 34 16 38
I	Italy	71016 San Severo FG	Ianzano F. LLI Raffaele e Luigi	+39 - 0882 - 33 14 18
I	Italy	73020 Martignano (LE)	Coriano Tomasso Officina Meccanica	+39 - 0832 - 80 10 08
I	Italy	74015 Martina Franca (TA)	Fratelli Cannella SNC	+39 - 080 - 48 552 59
I	Italy	80026 Casoria (NA)	CO. MAC. S.R.L.	+39 - 081 - 7 59 42 76, 7 59 08 00
I	Italy	84069 Roccadaspide (SA)	Sforza Marcello	+39 - 0828 - 94 18 34
I	Italy	85043 Latronico PZ	Falabella Egidio	+39 - 0973 - 85 81 41
I	Italy	88074 Crotona	R.A.I.M. S.A.S.	+39 - 0962 - 2 28 69
I	Italy	95131 Catania	Coco Gaetano di C. Mario e	+39 - 095 - 53 96 50
I	Italy	97100 Ragusa (RG)	Ricca S.R.L.	+39 - 0932 - 66 74 00
I	Italy	98071 Capo d'Orlando ME	Motagrind S.D.F. di Mangano & Scarvaci	+39 - 0941 - 90 19 59
IL	Israel	81100 Yavne, Israel	Shatal Engineering Ltd.	+972 - 8 - 9 32 02 20
IND	India	110008 New Delhi	SKL (India) Pvt. Ltd.	+91 - 11 - 25896075
IND	India	400072 Mumbai	SKL (India) Pvt. Ltd.	+91 - 22 - 28 47 66 49

IQ	Tehran	Mr. B. Amyari	+98 - 9123152982	
IR	Iran	Mr. B. Amyari	+98 - 9123152982	
IRL	Ireland	T.B.F. Thompson	+44 - 2890 - 84 83 71	
IRL	Ireland	T.B.F. Thompson	+44 - 28 - 29 55 83 53	
IS	Iceland	Taekjasalan ehf.	+35-4-5672520	
J	Japan	Tominaga & Co., Ltd	+81 - 3 - 36 39 - 53 11	
JOR	Jordan	Al Ghanem	+962 - 6 - 4 39 51 55	
KAZ	Kazakhstan	EngineService		
KAZ	Kazakhstan	EngineService	+7(7172) 73 80 73	
KAZ	Kazakhstan	Engine Service	+7 - 727 - 3 41 01 10	
KAZ	Kazakhstan	EngineService	+7 (727) 321-83-31	
KH	768441 SINGAPORE	Please contact		
KSA	Saudi Arabia	Electrical Work & Maintenance	+966 - 2 - 6 91 66 55	
KWT	Kuwait	Sabah International	+965 - 4 81 82 43	
LT	Lithuania	PLLC MASTERMANN	+370 - 37 - 45 31 55	
LU	3090 OVERIJSE	BIA NV/SA	+32(0)2 689 28 11	
LV	Latvia	KONO Ltd.	+371 - 67 - 14 94 25	
MA	Morocco	SONACOM	+212 - 5 - 22 24 97 00	
MAL	Malaysia	Autorex Engineering & Trading	+603 - 80 61 06 68	
MAT	Martinique	Assistance 97	+596 - 5 96 50 30 00	
MAW	Malawi	Engineering and Foundry	+2651- 671241/672028	
MM	11041 Yangon	SINGTECH GLOBAL ENGINEERING & TRADING CO., LTD	+95 954 14	
873				
MOC	Mozambique	Maputo	ABC Trading Lda.	+258 - 21 - 30 92 79
MV	Maldives	Male	MA Services Pvt. Ltd.	+960 - 3 31 09 35
N	Norway	5962 Bjordal	Østerbø Maskin AS	+47 - 48161718
NAM	Namibia	Windhoek	ConServ Engineering Services C.C.	+264 - 61 - 23 63 36
NEP	Nepal	3311 JC Dordrecht	Machiniefabriek Dolderman BV	+31 - 78 - 6 13 82 77
NEP	Nepal	4104 AE Culemborg	HATZ Nederland BV	+31 - 345 - 47 00 40
NEP	Nepal	8013 NE Zwolle	Janal Engineering BV	+31 - 38 - 4 60 22 00
NEP	Nepal	9301 ZV Roden	Ausma Motorenrevisie B.V.	+31 - 50 - 5 01 60 28
NZ	New Zealand	Auckland, New Zealand	Youngman, Richardson and Co. Ltd.	+64 - 9 - 4 43 24 36
OM	Oman	Al-Mlawaleh South, Al-Seeb	INMA CO. OMAN LLC	00968 24552455
P	Portugal	2130-111 Benavente - Lisboa	Pinto & Cruz - Motores e Equipamentos, S.A.	+351 21 7 11 21 00
P	Portugal	4100-320 Porto Codex	Pinto & Cruz - Motores e Equipamentos S.A.	+351 - 22 - 6 15 05 58
PA	Panama	Panamá 5	Dimar, S.A.	+507 - 2 29 14 44
PE	Peru	Lima 03	Or Maquinarias S.A.C.	+51 - 1 - 479/8170, 8265
PL	Poland	03-046 Warszawa	Full Sp. Z o.o.	+48 - 22 - 8 19 40 40
PL	Poland	30-732 Krakow	Wakbud Sp. Z o.o.	+48 - 12 - 6 53 25 37
PL	Poland	41-803 Zabrze	Wobis	+48 - 32 - 2 75 32 26
PL	Poland	55-010 Zerniki Wroclawskieawskie	Maszyny Budowlane "JAS"	+48 - 89 - 5 34 59 74
PL	Poland	84-122 Zelistrzewo	E.M.A. Hochschulz S.C.	+48 - 58 - 6 73 60 80
PL	Poland	85-549 Bydgoszcz	Technet S.C.	+48 - 52 - 3 70 70 90
PL	Poland	95-002 Smardzew	Broker - Serwis	+48 - 42 - 7177868; 7177883; 7177895
PNG	Papua New G.	2164 Smithfield NSW	please contact:	+61 - 2 - 8788 7999
Q	Qatar	Doha	INMA Company - Qatar L.L.C.	+974 - 4 - 43 00 88



HATZ service network

RA	Argentina	S 2252 BMR Galvez (Santa Fé)	Bounous Hnos S.A.	+54 - 3404 - 48 16 10
RB	Botswana	Gaborone	Orbit Pumps (Botswana) (Pty.) Ltd.	+267 - 397 49 26
RB	Botswana	Gaborone	Franklin Electric	+00 267 397 4926
RC	Taiwan	768441 Singapore	EquipSource Pte Ltd	+65 - 67 59 22 96
RCB	Congo	3689 Kinshasa-Gombe	Bureau Technique BIA sprl	+243 - 81 - 1 60 23 95
RCH	Chile	Santiago	Tecnica de Maquinarias Ltda.	+56 - 22 - 7 82 92 75
REU	Réunion	94099 RUHSTORF	MOTORENFABRIK HATZ GMBH & CO.KG	+49 8531 319 425
RI	Indonesia	50141 Semarang	PT URIP GUMULYA	+62 024 762 1195
RIM	Mauritania	Nouakchott	SODEQ S.A.	+222 - 5 25 47 30
RL	Lebanon	1102-2070 Beirut	Nagib Baki & Sons	+961 - 1 - 36 52 62
RM	Madagascar	Tananarive	Société Ameca	+261 - 20 - 2 22 30 16
RMM	Mali	Bamako	Dupé S.A.	+223 - 2 21 52 30
RO	Romania	012051 Bucharest	Fland Gruppe srl.	+40 - 21 - 3 36 11 30/ -50
ROK	Korea	150-972 Seoul-Youngdeungpo-Gu	U-YOUNG INDUSTRIAL CO.LTD.	+82 2 549 0611
ROU	Uruguay	12900 Montevideo	Bromberg y Cia. S.A.	+598 - 2 - 3 55 77 70
RP	Philippines	Quezon City	M & W Distributing Co. Inc.	+63 - 2 - 3 71 19 36
RS	Serbia	11120 Beograd	IWE d.o.o.	+381 - 11 2 76 65 65
RT	Togo	94099 RUHSTORF	MOTORENFABRIK HATZ GMBH & CO.KG	+49 8531 319 425
RU	Burundi	Bujumbura	Metalubia	+257 - 22 - 23 30
RUS	Russia	129336 Moscow	Stend Ltd.	+7 - 495 - 4 74 60 31
RUS	Russia	193315 Sankt-Petersburg	MKSM-Servis Spb	+7 - 812 - 309 03 80
RUS	Russia	346405 Nowotscherkassk	AUTOENERGIESYSTEME	+7 - 8635 - 23 42 91
RUS	Russia	390028 Ryazan	PromDizel Limited Corp.	+7 - 4912 - 33 24 45
RUS	Russia	414040 Astrakhan	AstraDieselService	+7 (8512) 31-75-35, 31-75-45
RUS	Russia	600026 Vladimir	EuroDiesel-Rus Ltd.	(4922) 37-60-45
RUS	Russia	628404 Surgut	MKSM - Servis Surgut	+7 - 3462 - 67 33 06
RUS	Russia	640007 Kurgan	Ural-Hatz-Diesel	+7 - 3522 - 54 54 50
S	Sweden	13650 Haninge	Swedmotor AB	+46 - 8 - 50 01 21 40
S	Sweden	23841 Oxie	Limhamns Industriservice AB	+46 - 040 306102
S	Sweden	393 65 Kalmar	Maskinteknik i Kalmar AB	+46 0480 478850
S	Sweden	417 55 Göteborg	Blombergs Diesel & Motor AB	+46 031 221220
S	Sweden	574 35 Vetlanda	Högländets Maskin Skog Entreprenad AB	+46 0383 763034
S	Sweden	59017 Mantorp	Allservice Mantorp	+46 - 070 5954300
S	Sweden	623 77 Klintehamn	Cedergrens Mek. Verkstad AB	+46 0498 241720
S	Sweden	77497 Fors	Tekzone AB	+46 070 6282277
S	Sweden	782 75 Malungfors	Reijo maskinservice AB	+46 0280 40328
S	Sweden	836 94 As	Nordisk teknik AB	+46 070 3105070
S	Sweden	863 33 Sundsbruk	Mattfors Truck service AB	+46 070 5702524
S	Sweden	922 31 Vindeln	Vindelns maskinservice AB	+46 070 6077812
S	Sweden	931 70 Skelleftea	Skelleftea El & Diesel AB	+46 0910 711111
S	Sweden	942 36 Älvsbyn	All Mecanservice AB	+46 0929 57012
S	Sweden	98138 Kiruna	Wist Last & Buss Ab	+46 - 980/398400
S	Sweden	98238 Gällivare	Holmgrens Truck & Motor AB	+46 - 970 - 74540
SGP	Singapore	768441 Singapore	EquipSource Pte Ltd	+65 - 67 59 22 96
SK	Slavakia	91501 Nové Mesto n. Váhom	RAMIRENT spol. s r.o.	+421 - 032 - 77 15 49 7
SLO	Slovenia	2000 Maribor	VZDRZEVANJE NEJC, D.O.O.	+386 - 2 - 420 11 98

HATZ service network



SME	Suriname	94099 Ruhstorf	Motorenfabrik Hatz GMBH & CO. KG	+49 (0)8531 319 373
SN	Senegal	Dakar	MATFORCE	+221 - 33 864 95 00
SYR	Syria	- Damascus	Electromechanical Equipment	+963 - 11 - 2 21 39 55 / 2 21 56 78
TAH	Tahiti	98701 Arue	Ets. Dieumegard	+689 - 6 89 42 32 38
THA	Thailand	10120 Bangkok	General Diesel (Thailand) Co. Ltd.	+662 - 2 94 08 75 - 6, 2 84 08 28
TN	Tunesia	1001 Tunis	S.I.A Ben Djemaa & Cie	+216 - 71 24 25 66
TN	Tunesia	3000 Sfax	S.I.A Ben Djemaa & Cie	+216 - 74 40 84 09
TR	Turkey	34852 Maltepe Istanbul Turkey	Efes Makina Sanayi ve dis Ticaret Ltd. STI	+90 - 216 - 3 67 35 75
TT	Trinidad and Tob.	San Fernando	Electrodiesel & Co. Ltd.	+1 - 868 - 652 - 37 10
UA	Ukraine	03313 Kiev	ERA - Engineering Remake Aggregate	+380 - 44 - 5 99 16 44
UAE	United Arab. Em.	Dubai	INMA	+971 - 4 - 2 85 72 72
USA	United States	08016 Burlington, NJ	Melton Sales & Service, Inc.	609/699-4800
USA	United States	WI 53187-0258 Waukesha	HATZ Diesel of America, Inc.	+1 - 262-544-0254
UZB	Uzbekistan	100011 Tashkent	Kartash Profservice	+998 - 7 11 203090
VN	Vietnam	768441 Singapore	Please contact our agent in Singapore	+65 - 67 59 22 96
WAL	Sierra Leone	Freetown	cerra automotive	+232 - 77 - 23 21 72
WAN	Nigeria	- Lagos	A1 Multi Services Limited	+234 803 7 123 006
YAR	Rep. of Yemen	Sana'a	Al Mahfadi Company Ltd.	+967 - 1 - 22 47 66, 22 25 29
YV	Venezuela	Caracas	Maquinarias Larraq, C.A.	+58- 212 - 9 44 16 31 / 9 44 56 29
ZA	South Africa	Bloemfontein	CPR Maintenance CC	+27 - (0)51 - 4 47 96 18
ZA	South Africa	Capetown	Compaction & Industrial Equipment C.C.	+27 - (0)21 - 9 49 77 67
ZA	South Africa	East London	Construction Equipment Supplies	+27 (0)43 748 4077
ZA	South Africa	Edenvale	Hatz Diesel (S.A.) Pty. Ltd.	+27 - 11 - 5 74 09 00
ZA	South Africa	Port Elizabeth	S & K Diesels cc	+27 - 41 - 5 83 37 80
ZW	Zimbabwe	Harare	R & S Diesel Pro Services (PVT) Ltd.	+263 - 4 44 78 69 / 90 / 99

Serial-code modification list
Serien-Nr.-Änderungen
Modification des Nos de serien
Modificación de los Nos de serie
Modifica dei codici

IMT-No.

4H50 TIC (Serial No. 136 xx)

4H50TIC.10	4H50TIC.11	15.717
------------	------------	--------