

ISUZU DIESEL ENGINE
3CC1, 3CD1, 3CD1T, 3CE1

INSTRUCTION MANUAL

ISUZU MOTORS LIMITED

CALIFORNIA

Proposition 65 Warning

Diesel engine exhaust and some of its constituents are known to the State of California to cause cancer, birth defects, and other reproductive harm.

FOREWORD

The ISUZU industrial diesel engines are a product of ISUZU's long years of experience, advanced technology. ISUZU takes great pride in the superior durability and operating economy of these engines.

In order to get the fullest use and benefit from your industrial engine, it is important that you operate and maintain it correctly. This Manual is designed to help you do this.

Please read this Manual carefully and follow its operating and maintenance recommendations. This will ensure many years of trouble-free and economical engine operation.

Should your engine require servicing, please contact your nearest ISUZU engine outlet. He knows your engine best and is ready to meet your satisfaction.

All information, illustrations, and specifications contained in this Manual are based on the latest product information available at the time of publication.

ISUZU reserves the right to make changes in this Manual at any time without prior notice.

Thank you for purchasing the ISUZU product.

[INTRODUCTION]

- This Instruction Manual describes the operation, maintenance and inspection of the 3CC1 • 3CD1 • 3CD1T • 3CE1 diesel engines.
- Read this Instruction Manual carefully before operate the machine unit to ensure that the engine is used correctly and that it stays in the best possible condition.
- Keep this Instruction Manual in a convenient place for easy access.
- If this Instruction Manual is lost or damaged, order a new one from your dealer or Isuzu distributor.
- Make sure this manual is transferred to subsequent owners. This manual should be considered a permanent part of the engine and remain it.

- Constant efforts are made to improve the quality and performance of Isuzu products, so some details included in this Instruction Manual may differ slightly from your engine. If you have any questions about such difference, please contact your dealer or Isuzu distributor.
- The specifications and components (instrument panel, fuel tank, etc.) described in this manual may differ from ones installed in your machine unit. To obtain their information, please refer to the manual provided by the equipment manufacturers.

California

Proposition 65 Warning

Diesel engine exhaust and some of its constituents are known to the State of California to cause cancer, birth defects, and other reproductive harm.

California

Proposition 65 Warning

Battery posts, terminals, and related accessories contain lead and lead compounds, chemicals known to the State of California to cause cancer and reproductive harm.

Wash hands after handling.

The EPA (U.S. Federal) and Air Resources Board (ARB, California) Off-road Compression Ignition engines regulations

The engines for the EPA regulations will be used in the States, and the engines for the ARB regulations will only be used in the State of California.

The information on engines to comply with the EPA and ARB Regulations is released and you are kindly requested to make every effort to comply with them. Isuzu Engines of all "3C" series engine models are covered with these regulations.

Engine identification

With the regulations on engine emission worldwide, it has become necessary to identify engines in a manner to determine which regulations they comply with, hence

- Emission control information label as shown below which will contain:

IMPORTANT ENGINE INFORMATION	
THIS ENGINE CONFORMS TO <input type="checkbox"/> A <input type="checkbox"/> MODEL YEAR U. S. EPA REGULATIONS	
THIS ENGINE IS CERTIFIED TO OPERATE ON "US-2D" FUEL	
ENGINE FAMILY: <input type="checkbox"/> C <input type="checkbox"/>	DISPLACEMENT: <input type="checkbox"/> D <input type="checkbox"/> LITERS
ENGINE MODEL: <input type="checkbox"/> E <input type="checkbox"/>	EMISSION CONTROL SYSTEM: <input type="checkbox"/> F <input type="checkbox"/>
FUEL RATE: <input type="checkbox"/> G <input type="checkbox"/> MM ³ /STROKE @ <input type="checkbox"/> H <input type="checkbox"/> KW/ <input type="checkbox"/> I <input type="checkbox"/> RPM	
REFER OWNER'S MANUAL FOR MAINTENANCE SPECIFICATIONS AND ADJUSTMENTS	

EPA Emission Control Label

IMPORTANT ENGINE INFORMATION	
THIS ENGINE CONFORMS TO <input type="checkbox"/> H <input type="checkbox"/> M. Y. CALIFORNIA AND U. S. EPA REGULATIONS FOR OFF-ROAD C. I. ENGINES.	
THIS ENGINE IS CERTIFIED TO OPERATE ON 'Type 2-D' FUEL	
ENGINE FAMILY: <input type="checkbox"/> B <input type="checkbox"/>	DISPLACEMENT: <input type="checkbox"/> C <input type="checkbox"/> LITERS
ENGINE MODEL: <input type="checkbox"/> D <input type="checkbox"/>	EMISSION CONTROL SYSTEM: EM
FUEL RATE: <input type="checkbox"/> E <input type="checkbox"/> MM ³ /STROKE @ <input type="checkbox"/> F <input type="checkbox"/> KW/ <input type="checkbox"/> G <input type="checkbox"/> RPM	
REFER TO OWNER'S MANUAL FOR MAINTENANCE SPECIFICATIONS AND ADJUSTMENTS.	

EPA/ARB-OR Emission Control Label

- Engine family name as assigned by EPA and ARB identifying engine family group 3YDXL1.5M3N and this identifies

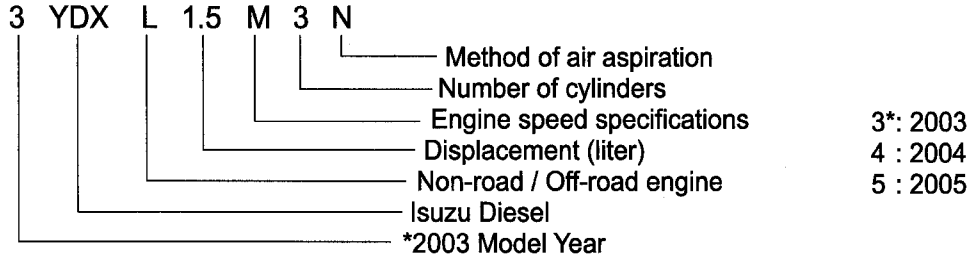

- Label location:

The typical location of this label for each engine is on the "top of rocker arm cover"

A supplemental label may be used in certain applications for improved visibility.

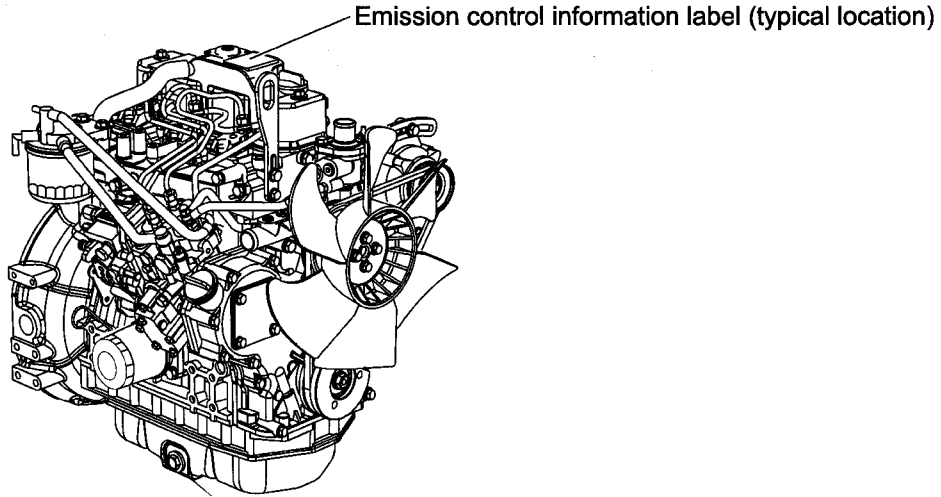

Requirements on engine installation condition

The followings are required from the point of view of engine installation in order to comply with the EPA and ARB regulations. Unless otherwise satisfying these, engines exhaust gas emission will not be within the regulated value of the EPA and ARB Regulations.

- Maximum Exhaust Gas Restriction shall be
15.29 kPa (1560mm H₂O) or less for 3CC1, 3CD1, 3CE1.
5.88 kPa (600mm H₂O) or less for 3CD1T.
- Maximum air intake restriction shall be 6.2kPa (635mm H₂O) or less and clean air cleaner element each time when air intake restriction exceeds the above mentioned value.

Emissions-related parts

The EPA and ARB regulates specific emissions-related parts to be warranted for the period in the following table. However, ultimate purchasers are obligated to use and maintain the engine correctly.

Warranty Periods

Power Range kW (Gross power)	Other than Constant-speed	Constant-speed
		Under 3000 min ⁻¹
Range < 19		1500 hours or 2 years
19 ≤ Range < 37		3000 hours or 5 years

*Actual hours or years of operation whichever occurs first is applied.

The specific emissions-related parts are

- Fuel injection nozzle
- Fuel injection pump
- Turbocharger

Maintenance schedule

To maintain optimum engine performance and compliance with the EPA Regulations Non-road Engines, it is necessary that the maintenance schedule is adhered to. Regular scheduled maintenance is a major key to engine service life and emissions regulations compliance. It is of utmost importance that scheduled maintenance, requirements are performed on a timely basis.

EPA allows to apply Maintenance schedule for Emission related parts as follows.

—	Check Fuel Injection Nozzle and clean	Adjust, cleaning and repair of Fuel Injection Pump and Fuel Injection Nozzle
kW \leq 130	1500 hours of use and at 1500-hour intervals thereafter	3000 hours of use and at 3000-hour intervals thereafter

Maintenance schedule not related to emissions is recommended in 5.2 List of Periodic Inspection.

Emission System Warranty Statement

U.S. EPA and CALIFORNIA EMISSIONS CONTROL WARRANTY STATEMENT

Isuzu Motors Limited warrants initial owner and each subsequent owner that the engine is designed, built and equipped so as to conform with applicable regulations for its warranty period.

Specific emissions-related parts and components are warranted for the period specified in "**Emissions-related parts**" whichever comes first, after the date of delivery to the initial owner. If any emissions-related part is defective during the warranty period, Isuzu will repair your engine at no cost to you including diagnosis, parts and labor.

To maintain engine performance and compliance with the regulations, the owner is responsible for the performance of the required maintenance listed in the instruction manual during the warranty period.

This emission warranty does not cover:

1. Failure caused by any of the following:

- Abuse, neglect, improper maintenance or use of non-genuine parts.
- Use of fuel oil and lubricating oil not recommended for the engine.
- Improper application and installation.

2. Add-on or modification affecting engine emissions.

The use of add-on or modified parts can be grounds for disallowing a warranty claim.

Isuzu is not liable to cover failures of the emission control system parts or components caused by the use of add-on or modified parts.

The 97/68/EC Directive Certified engines

The engines in this manual have been certified by the 97/68/EC Directive.

To identify the engines, the following emission control label is affixed on the engines.

IMPORTANT ENGINE INFORMATION	
THIS ENGINE CONFORMS TO 97/68/EC DIRECTIVE	
ENGINE FAMILY :	<input type="text" value="A"/>
ENGINE MODEL :	<input type="text" value="B"/>
APPROVAL NUMBER:	<input type="text" value="C"/>

EC Emission Control Label

- Label location:

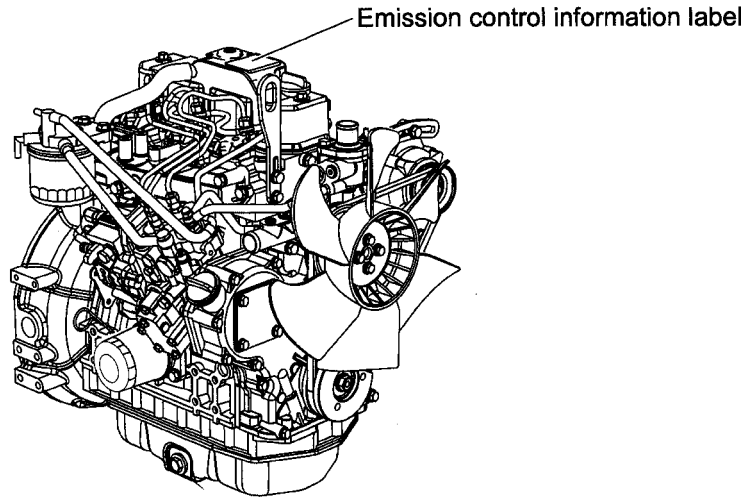

INDEX

page No.

1 FOR YOUR SAFETY	1
1.1 Warning Symbols	1
1.2 Safety Precautions	3
2 PRODUCT OVERVIEW	15
2.1 Intended Uses and Conditions	15
2.2 Names of parts	17
2.3 Functions of Major Parts	19
2.4 Control Equipment	22
2.4.1 Instruments and alarm devices	22
2.4.2 Operation Device	24
3 BEFORE OPERATION	29
3.1 Fuel Oil, Engine Oil and Cooling Water	29
3.1.1 Fuel oil	29
3.1.2 Engine oil	31
3.1.3 Cooling water	32
3.2 Supplying Fuel	34
3.2.1 Filling the fuel tank	35

3.2.2 Bleeding the fuel system	36
3.3 Supplying Engine Oil	38
3.4 Supplying Cooling Water	40
3.5 Checking the Engine Oil and Cooling Water	43
4 OPERATION INSTRUCTIONS	45
4.1 Check before Daily Operation	48
4.2 Checking the Control Panel and Alarm Devices	51
4.2.1 Checking alarm lamps	51
4.2.2 Checking the instruments (meters)	53
4.3 Starting	54
4.3.1 Daily starting the engine procedure	55
4.3.2 Warming up running	56
4.3.3 Starting up the engine at low ambient temperature	57
4.3.4 Restarting after starting failure	58
4.3.5 After the engine has started	58
4.4 Adjusting the Engine Speed	59
4.5 Check during Operation	60
4.6 Stopping the Engine	62
4.7 Taking Care during Long-term Storage	64
4.7.1 Inspection and maintenance during long-term storage	64
4.7.2 Checking the engine for reuse after long storage period	65
5 MAINTENANCE	67
5.1 Precaution for Inspection	67

5.2 List of Periodic Inspections	69
5.3 Periodic Inspection Items	72
5.3.1 Inspection after initial 50 hours operation	72
5.3.2 Inspection every 50 hours operation	77
5.3.3 Inspection every 250 hours operation	81
5.3.4 Inspection every 500 hours operation	86
5.3.5 Inspection every 1000 hours operation	89
5.3.6 Inspection every 2000 hours operation	91
5.3.7 Checking and adjusting the EPA emission related parts	92
6 TROUBLESHOOTING	93
7 ENGINE SPECIFICATIONS	97
7.1 General	97
7.2 Principal Engine Specifications	99

1. FOR YOUR SAFETY

(Please make sure to read and fully understand the description for safety)

Following the precautions described in this manual will enable you to use this engine with complete satisfaction. Failure to observe any of the rules and precautions, however, may result in injury, burns, fires, and engine damage. Read this manual carefully and be sure fully understand it before beginning operation.

1.1 Warning Symbols

These are the warning symbols which are used in this manual and on the products. Symbols and their meanings are as follows.



DANGER- Indicates an imminently hazardous situation which, if not avoided, **WILL** result in death or serious injury.



WARNING- Indicates a potentially hazardous situation which, if not avoided, **COULD** result in death or serious injury.



CAUTION- Indicates a potentially hazardous situation which, if not avoided, **MAY** result in minor or moderate injury.

1. FOR YOUR SAFETY ——— 2

- The failure to comply with all relevant Safety Instructions could result in bodily injury.
- The descriptions captioned by **IMPORTANT** are particularly important cautions for handling. If you ignore them, the performance of your engine and machine unit may be deteriorated leading to trouble. It may also be used to alert against unsafe practices.

Warning indications on this engine (safety labels, etc.) are also shown on your machine unit side. Make sure to also observe warnings indicated on the machine unit and instructions contained in the instruction manual supplied from the machine unit manufacturer.

Keep the warning labels affixed on the engine and machine unit from becoming dirty or torn. If a warning label is missing, damaged or cannot be read, it must be promptly replaced, ordering it in the same way as for the service parts. Also, if a warning label is affixed on a part which is replaced, a new warning label must be affixed on the replaced part.

1.2 Safety Precautions

(These instructions should be strictly followed for the safety of you and others.)

1.2.1 Precautions for operation

⚠ DANGER



Preventing burns from scalding

- Never open the radiator filler cap shortly after shutting the engine down. Steam and hot water will spurt out and seriously burn you. Allow the engine to cool down before attempt to open the filler cap.
- Securely tighten the filler cap after checking the radiator. Steam can spurt out during engine running, if tightening loose.

⚠ DANGER



Sufficient ventilation of the battery area.

- Keep the area around the battery well ventilated, paying attention to keep sparks, open flame and any other form of ignition away. During engine running or charging battery, hydrogen gas is produced from the battery and can be easily ignited.

⚠ DANGER



Preventing fire

- Be sure to use the proper diesel fuel. Filling with gasoline or the like by mistake will result in ignition.
- Be sure to stop the engine before refueling.
- If you spill fuel, wipe off such spillage completely.
- Never place oil or other flammable materials (such as straws, withered grass) close to the engine during running or shortly after shutting it down.
- Check fuel oil and engine oil for leakage from their piping lines to cause fires. Replace the rubber hoses with new ones every 2 years even if storing without use.
- Start the engine only from a starter switch without any load or in neutral position of the clutch of machine unit. Starting by means of connecting with the terminals of starter motor using a screwdriver or the like (jumping start) may cause fire due to spark at the terminals of starter motor. Also, the machine unit suddenly starts to move or generates power to cause serious personal injury.
- Keep the engine (machine unit) sufficiently away from a building and flammable materials during engine running. It may cause fires due to hot exhaust gas and engine body.
- Keep sparks, open flames or any other form of ignition (match, cigarette, etc.) away when fueling / refueling. Fire and or an explosion may result.

⚠ WARNING



Preventing exhaust fumes inhalation

- Never block up windows, ventilation ports, or other ventilation equipment such as ventilators of the engine room. Ensure good ventilation during engine operation. Inhaling the exhaust fumes is harmful.
- Never operate the engine in a closed room, tunnel, underground room, manhole or ship's hold. It is dangerous since exhaust fumes cannot get out.

⚠ WARNING

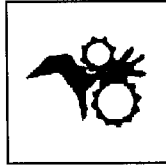

Keep away from moving / rotating parts

- Pay sufficient attention so as not to touch moving / rotating parts, or bring your hands or part of your body or clothes close to moving / rotating parts while the engine is running. Otherwise, you may get injured by being caught by the cooling fan, fly-wheel or PTO shaft. Never operate the engine without covers on the moving / rotating parts. Also, always keep kids and pets away from the engine and machine unit.
- Check before starting the engine to see that any tools or cloths used in the maintenance have been removed from the area.

⚠ CAUTION

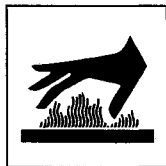

Preventing burn from contacting with hot surface

- Pay sufficient attention not to bring part of your hand and body or clothes in contact with the silencer, exhaust pipe, turbocharger and engine body during operation or shortly after stopping the engine.

The whole engine is hot and scalding / serious burns may result.

- Carry out cooling down engine running for 5 minutes without load before the engine has been stopped. Sudden shutting the engine down without any cooling down running causes the engine and around temperature to rise rapidly. Scalding / serious burns or fires may result.

⚠ WARNING

Never operate the engine while you are under the influence of alcohol

- Also, never operate the engine when you are ill or feel unwell as this results in unexpected accidents.

⚠ CAUTION

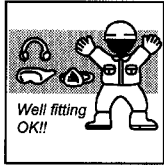

Safe work clothing

- Appropriate safety wear (gloves, special shoes / boots, eye / ear protection, head gear, harness' clothing, etc.) should be used / worn to match the task at hand. Avoid wearing jewelry, unbuttoned cuffs, ties or loose fitting clothes around moving machinery. A serious accident may occur if caught in moving / rotating machinery.
- Do not operate the engine and machine unit wearing earphone or headphone to listen to music or radio. A serious accident may occur because it is difficult to hear a warning from outside.

1.2.2 Precautions for inspection

⚠ DANGER



Do not come in contact with battery electrolyte

- Batteries contain sulfuric acid. Do not allow it to come in contact with clothing, skin and or eyes, severe burns will result.

Always wear safety goggles and protective clothing when servicing the battery. If contact with the skin and or eyes should occur, flush with a large amount of water and obtain prompt medical treatment.

⚠ DANGER



- Do not intentionally make the battery spark by short-circuiting to check its remaining charge. It will cause fires.

Make sure to use a gravimeter to check the remaining charge of the battery.

- If the battery electrolyte frozen, recharge the battery after warming up to thaw it. It will cause explosion.

Do not expose your skin to high pressure fuel spray

- Be careful so as not to bring your skin in contact with high pressure fuel spray from broken fuel injection pipe to penetrate your skin to cause inflamed.

If exposing to the spray should occur, obtain prompt medical treatment.

When any leakage of high pressure fuel spray is found during engine running, intercept it with a wooden plate, etc. so as not to be exposed your skin to it and shut the engine down and ask your dealer or Isuzu distributor for repair.

⚠ WARNING



Preventing electric short-circuits

- Make sure to turn off the battery switch or disconnect the negative cable (-) before inspecting the electrical system. Failure to do so could cause short-circuiting and fires.
- Check the electric lead wires for any slackened, twisted, damaged and keep the connectors and terminals of wire harness clean. They may cause fires due to electric short-circuit.

⚠ WARNING



Keep off moving / rotating parts

- Stop the engine before starting service operation. If you must inspect while the engine is operating, never bring your hand, body or clothing in contact with or close to moving / rotating parts, as you may get injured by being caught by moving / rotating parts.

⚠ CAUTION

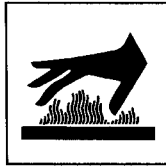

Preventing scald from draining hot oil and water

- If engine oil must be drained from the engine while it is still hot, take care not to let the oil splash on you to avoid scalding.
- Wait until the temperature goes down before draining the coolant. Hot water may splash to burn you.

⚠ CAUTION

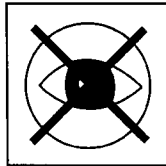

Beware of dirt from air blowing

- Wear protective equipment such as goggles to protect your eyes when blowing compressed air or steam. Dust or flying debris can hurt eyes.

IMPORTANT:

Keep away from lifting up or traveling engine

- *Lifting up or traveling the engine for a repair by yourself could result in serious injury. If you need any repair, ask your dealer or Isuzu distributor.*
- *Be sure to keep away from the traveling engine or the area beneath the engine which is lifted up.*

IMPORTANT:

Modification not authorized

Never modify this product or release the limit devices (which limit engine speed, fuel injection quantity, etc.).

Such modification or release will impair the safety and performance of the product and functions and result in shorter engine life. And be sure to use Isuzu genuine part when replace the part with new one.

IMPORTANT:

Waste management

Observe the following instructions with regard to hazardous waste disposal. Negligence of these will have a serious impact on environmental pollution concerns.

- *Waste fluids such as engine oil, fuel and coolant shall be carefully put into separate sealed containers and disposed of properly.*
- *Do not dispose of waste materials irresponsibly by dumping them into the sewer, overland or into natural waterways.*

1. FOR YOUR SAFETY ——— 12

- *Waste materials such as engine oil, fuel, coolant, solvents, filter elements and batteries, must be disposed of properly according to local ordinances. Consult the local authorities or reclamation facility.*

Never permit anyone to operate the engine and or machine unit without proper instruction.

- *Explain how to operate the engine and or machine unit to make fully understand the person from you when you let someone use it. At the same time, you let the one read this manual and the instruction manual for the machine unit to further understand how to operate.*

To keep the engine in the best condition

- *Avoid the engine running in the following surrounding conditions. Otherwise, the engine may cause to damage, to be not enough engine performance or to be shorten engine life.*
 - *In extreme dusty air.*
 - *In a harmful chemical gas or fumes.*
 - *In salty win (sea side).*
 - *Flooding place when raining.*
 - *Exposing the engine in raining.*
- *When steam cleaning or water cleaning the engine, protect the air cleaner and electric components from steam or water.*

- *It is essential to run your engine at the ambient temperature +45 ~ -15°C.*

If the temperature is higher than the above, the engine may have overheating and get the extreme high temperature engine oil to cause engine trouble.

Contrarily, If the ambient temperature is lower than the above, the engine components made of rubber are hardened to cause damage.

When you run the engine at the temperature out of the above, contact your dealer or Isuzu distributor. Also when you run the engine on higher sea-level land, the engine output may not be enough and runs with poor exhaust gas due to lower atmospheric pressure and lean air intake.

2. PRODUCT OVERVIEW

2.1 Intended Uses and Conditions

The environment friendly engine designed and controlled low exhaust gas emission, less noise and vibration has been delivered to you as a power source for civil, construction, agriculture, generator and other machine units.

- Easy starting with new developed fuel injection pump and combustion system.
- Economical running reduced fuel and engine oil consumption.
- Easy operation due to minimum maintenance and compact designed.
- Durable and reliable engine equipped with the new designed fuel injection valve and fuel injection pump.

We are sure that you will be satisfied with the above features.

Main power of this engine can be taken off from the flywheel end by means of "direct couple driving" or "belt driving". For direct couple drive engine, the flywheel housing or end plate to mount the engine to a machine unit is installed to the engine. For belt drive engine, the belt drive device equipped with a bearing is required so as not to damage the crankshaft and or main engine bearing. If you have need of the belt driving and or front power take-off device, please contact your dealer or Isuzu distributor.

The specifications of the main parts of the engine are standardized for multi-purpose application. Options (fuel tank, remote controller, instruments, alarms, etc.) are provided to meet various operating conditions. Since installation and fitting of the engine require special knowledge and skill, always consult your dealer or Isuzu distributor.

- Please consult with us for selecting optional parts. Optional parts should be selected to best match the work conditions and environments.
- To obtain the maximum engine performance with a minimum risk of machine troubles and accidents, it is very important to match the engine with the machine unit.
- Carefully establish safe exhaust piping, electric wiring, ventilation and accurate engine installation.
- Certain applications may require an inspection by the authorities.

This manual describes operation based on the standard specifications.
When coupled with the machine unit, operation procedures for options and accessories may vary depending on the structure of that machine unit.

OPTION : Information for optional parts.

ENGINE NAME : Information for exclusive matter of the engine.

For optional parts or accessories refer to the instruction manual provided by the equipment manufacturer and observe the instructions and cautions given therein.

2.2 Names of parts

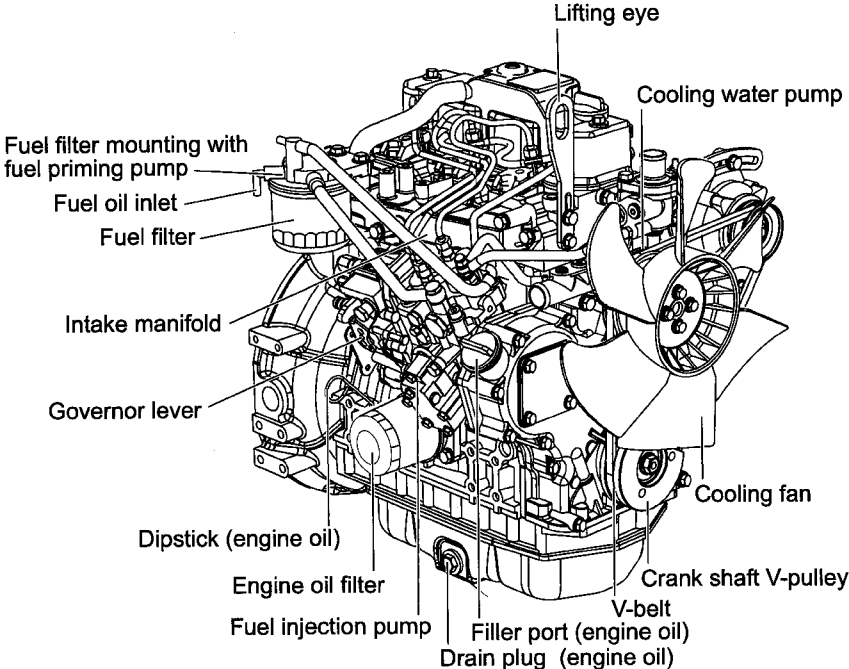

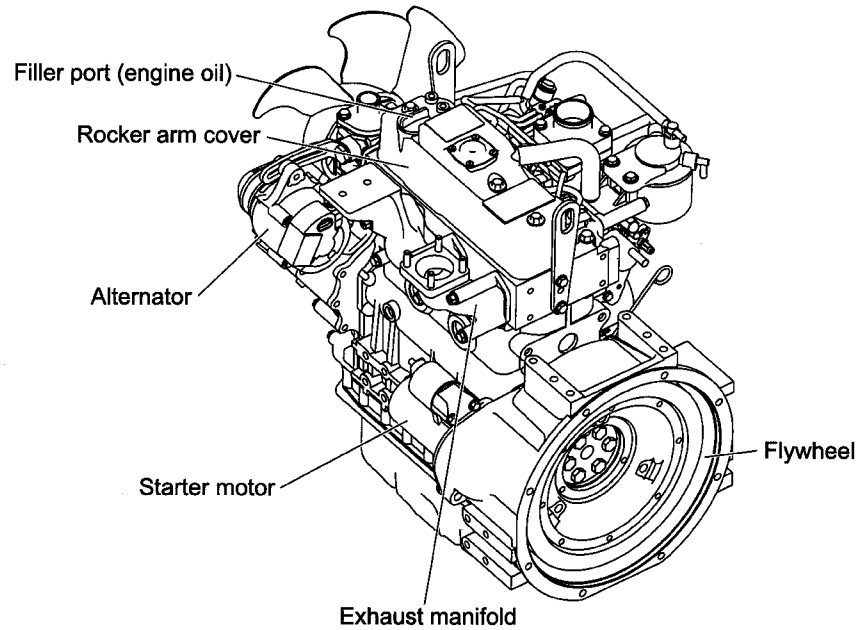

2.3 Functions of Major Parts

Parts	Functions
Fuel filter	Removes dirt and water from the fuel oil. Periodic replacement of filter element is necessary before it is clogged with dirt. Replace the whole cartridge assembly for renewal.
Oil / water separator	Stand alone type (fitted on the machine unit)(engine maker supplies). Drain the dust and water periodically from the drain cock at the bottom of the separator fitted near the fuel tank of the machine unit.
Fuel priming pump	The priming pump on the top of the fuel filter mounting feeds the fuel by moving the knob of the priming pump up and down by hand to bleed the air from the fuel system. (The fuel filter mounting with priming pump is optional). The fuel priming pump position on the fuel filter mounting should be on the lower level than the fuel tank position. The electro-magnetic fuel feed pump provided as optional should be fitted on the fuel piping when installing the fuel filter mounting without fuel priming pump to bleed the air and feed fuel to the fuel injection pump.
Fuel feeding pump	Electro-magnetic fuel feeding pump (DC12V) (optional) should be fitted on the fuel piping to bleed air and feed fuel to the fuel injection pump when installing the fuel filter mounting without fuel priming pump.
Filler port (engine oil)	Filler port for engine oil.
Dipstick (engine oil)	Level gauge for engine oil in the oil pan.

Parts	Functions
Engine oil filter	Filters fine metal fragments and carbon in the engine oil. The filter is a cartridge type and the filter element should be replaced before clogging occurs.
Air cleaner	Air intake device which drifting dust is prevented from entering the cylinder by means of the filter element, and it also serves to reduce the air intake noise. Periodic check (cleaning or replacement) of the filter element is necessary before it is clogged with dust.
<p>[Cooling water system]</p> <ul style="list-style-type: none"> •Radiator •Cooling fan and cooling water pump •Radiator cap •Sub-tank •Oil cooler (3CD1T) 	<p>This engine is water-cooled system by means of radiator. Serves as cooling water storage tank and heat exchanger. The cooling fan is driven by the V-belt to cool the cooling water. The cooling water pump circulates the cooling water through the cylinder block and cylinder head to cool them, and returns the water into the radiator.</p> <p>The radiator cap is equipped with two pressure regulating valves: the release and vacuum valves. When the cooling water temperature rises, the radiator inner pressure gets higher and the release valve opens to release steam and overflowing thermally expanded hot water into the sub-tank through a rubber hose. (Note that the rubber hose connects the water supply port and the sub-tank.)</p> <p>Steam and hot water delivered to the sub-tank are cooled down to water again. When the load is reduced and the cooling water temperature drops, the radiator internal pressure becomes nearly negative, and vacuum valve on the radiator cap opens to suck back the water in the sub-tank to the radiator. This cycle minimizes the cooling water consumption.</p> <p>Cools engine oil by cooling water to minimize the deterioration.</p>
Starter motor	The starter motor pinion powered by battery engages with the ring gear installed on the flywheel and turn it to start the engine.

Parts	Functions
Alternator	Driven by V-belt and generates electricity and charges the battery
Turbocharger (3CD1T)	The pressurized intake air feeding device to the cylinder. The turbine energized by exhaust gas rotates the blower.

2.4 Control Equipment

Control equipment described here includes monitoring the engine running conditions during operation, the devices for starting, adjusting the engine speed and stopping the engine.

2.4.1 Instruments and alarm devices

On the control panel for control equipment, following gauges and alarm devices could be installed.

(1) Instruments

- Ⓐ Tachometer (with integrated hour meter) **OPTION**
The needle shows the engine speed, Hour meter shows total operation hours in the window below the tachometer. Refer to the figure as a standard for periodic inspection.
- Ⓑ Cooling water temperature meter **OPTION**
The needle shows engine cooling water temperature.
- Ⓒ Engine oil pressure meter **OPTION**
The needle shows engine oil pressure.

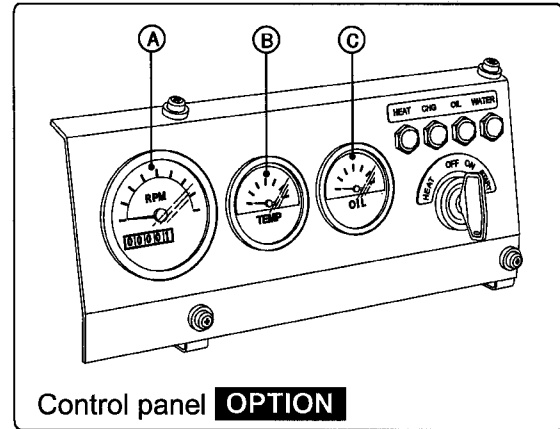

(2) Lamps**OPTION**

- Ⓓ Heat up indicating lamp for air heater.

(HEAT: Blue)

When the key is turned to the HEAT position to energize the air heater, the lamp comes on. After keeping it at the HEAT position for approx. 15 seconds, the lamp goes off to turn the key to the START position.

- Ⓕ Battery charge alarm lamp (CHG: Red)

The lamp is off while the battery is recharged. It comes on when the battery is not charged normally.

- Ⓖ Engine oil pressure alarm lamp (OIL: Red)

The lamp comes on if engine oil pressure drops below the specified.

- Ⓗ Cooling water temperature alarm lamp

(WATER: Red)

The lamp comes on if the cooling water temperature exceeds the specified (110°C or more).

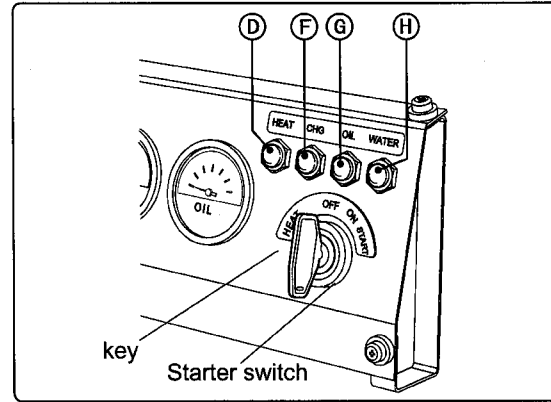

2.4.2 Operation Device

The devices for starting, adjusting the engine speed, and stopping the engine are as follows.

(1) Starter switch

OPTION

This is 3-stage rotary switch.

Position is changed by turning the key inserted to the slot of the starter switch.

OFF: This is the engine stop position, and all electric current is cut off. The key can be inserted and removed at this position.

ON: This position provides the normal operating condition.

Current flows to instruments and alarm devices.

START: This is the starting position. The starter motor rotates to crank the engine.

The key returns automatically to the ON when it is released.

HEAT: This position is used to energize the air heater. The key returns automatically to the OFF when it is released.

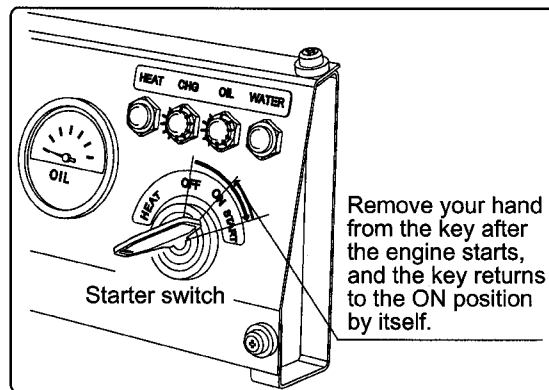

(2) Air heater (cold starting aid)

OPTION

Located on the intake manifold inlet, the air heater is heated up to start the engine easily under low temperature conditions.

After keeping the key at the HEAT position for approx. 15 seconds, the lamp goes off to turn the key to the START position.

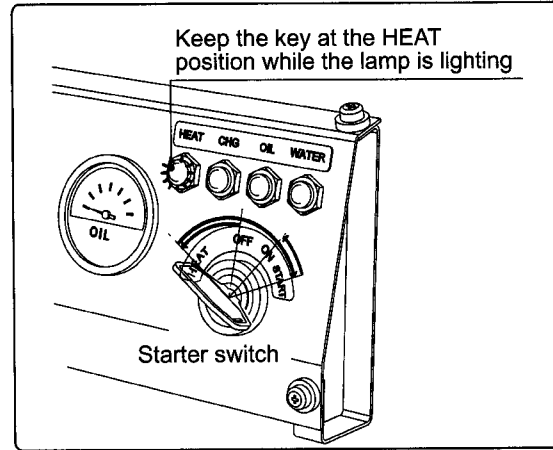

(3) Governor lever

This lever controls the engine speed via the speed control device of the machine unit.

It is linked with the accelerator system on the machine unit side (accelerator handle and pedal to be procured by the equipment manufacturer) by means of an accelerator wire for remote control.

High idling and low idling speed are restricted by their limiting bolt.

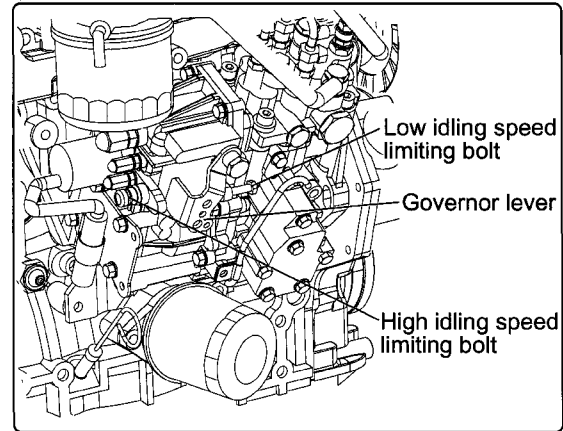

(4) Engine stopping device

When the key is turned to the OFF position, the engine stop solenoid actuates the valve of fuel injection pump to stop fuel.

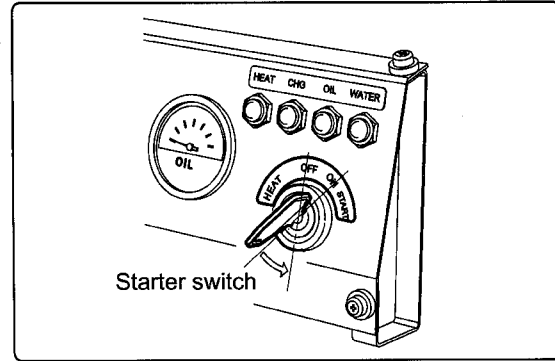

3. BEFORE OPERATION

Follow procedures in 3.1 through 3.5 for preparation before starting the engine.

The engine of no contained fuel oil, engine oil and cooling water will be delivered from Isuzu engine factory. If containing them in your engine equipped in the machine unit, read this section carefully to fully understand the required fuel oil, engine oil, cooling water and how to fill with them.

3.1 Fuel Oil, Engine Oil and Cooling Water

3.1.1 Fuel oil

IMPORTANT:

Only use the recommended fuel to obtain the best engine performance and prevent damage of parts, also prevent air pollution.

(1) Selection of fuel oil

Use the following diesel fuels for best engine performance:

BS 2869 A1 or A2

Fuels equivalent to Japanese Industrial Standard, JIS. No. K2204-2

Cetane fuel number should be 45 or greater

(2) Fuel handling

- Water and dust in the fuel oil can cause operation failure.

Use containers which are clean inside to store fuel oil. Store the containers away from rain water and dust.

- Before supplying fuel, let the fuel container rest for several hours so that water and dust in the fuel are deposited on the bottom. Pump up only the clean fuel.

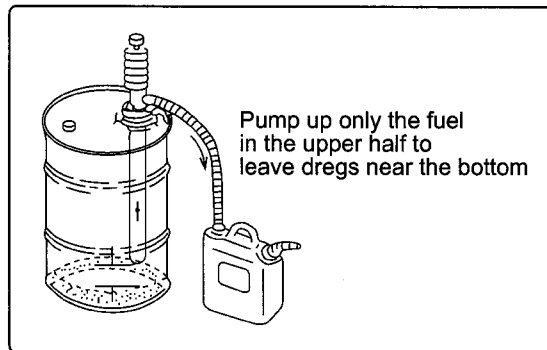

(3) Fuel tank

OPTION

Be sure to attach a drain cock, precipitation trap and primary strainer to the fuel tank as shown illustration right.

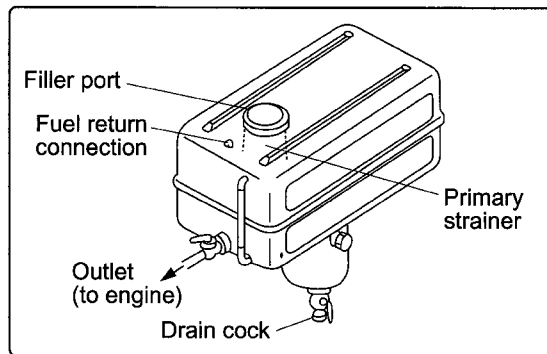

3.1.2 Engine oil

IMPORTANT:

Use of other than the specified engine oil may cause inner parts seizure or early wear, leading to shorten the engine service life.

(1) Selection of engine lube oil

use the following engine oil

- API classification CD or CF
(Standards of America Petroleum Institute)
 - SAE viscosity 10W-30 or 15W-40
(Standard of Society of Automotive Engineering)
- Engine oil with 10W-30 or 15W-40 can be used throughout the year.
(Refer to the shown right.)

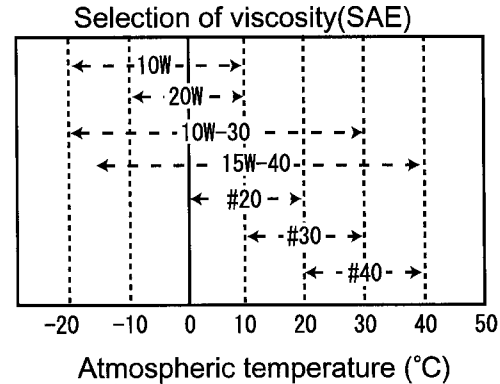

(2) Handling of engine oil

- Carefully store and handle the oil so as to prevent dust or dirt entrance. When supplying the oil, pay attention and clean around the filler port.
- Do not mix different types of oil as it may adversely affect the lubricating performance.

⚠ CAUTION

Contact with engine oil may result in the roughened skin. Care should be taken so as not to contact with engine oil wearing protective gloves and clothing. If contact, wash with soap and water thoroughly.

3.1.3 Cooling water

Use clean soft water and be sure to add the Long Life Coolant Antifreeze (LLC) in order to prevent rust built up and freezing. If there is any doubt over the water quality, distilled water or pre-mixed coolant should be used. The coolants / antifreezes, which are good performance for example, are shown below.

- TEXACO LONG LIFE COOLANT ANTIFREEZE, both standard and pre-mixed.
Product codes 7997 and 7998
- HAVOLINE EXTENDED LIFE ANTIFREEZE / COOLANT
Product code 7994

IMPORTANT:

- *Be sure to add Long Life Coolant Antifreeze(LLC) to soft water. In cold season, the LLC is especially important. Without LLC, cooling performance will decrease due to scale and rust in the cooling water line. Without LLC, cooling water will freeze and expand to break the cooling line.*
- *Be sure to use the mixing ratios specified by the LLC manufacturer for your temperature range.*
- *Do not mix different types (brand) of LLC, chemical reactions may make the LLC useless and engine trouble could result.*
- *Replace the cooling water every once a year.*

 CAUTION

When handling Long Life Coolant Antifreeze, wear protective rubber gloves not to contact with it. If contact with the eyes or skin should occur, wash with clean water.

3.2 Supplying Fuel

⚠ CAUTION



(Refer to 3.1.1.Fuel)

- Be sure to use the correct type of fuel when fueling / refueling. Mistakenly filling with gasoline or the like will result in ignition.
- Never refuel while the engine is running. If you spill fuel, wipe off such spillage completely.
- Never place oil or other flammable material close to the engine as this could result in ignition.
- Keep sparks, open flames or any other form of ignition (match, cigarette, etc.) away when fueling / refueling. Fire and or an explosion may result.

3.2.1 Filling the fuel tank

Fill the tank with clean fuel which has not been contained with water or dust. Do not remove the primary strainer from the filler port when fill the fuel tank. If remove, trash or dust could get into the fuel tank to cause fuel pipe line clogging. Overfilling is dangerous. Do not fill the tank beyond the full mark of the fuel gauge. Be sure to fill the fuel tank at well ventilated place.

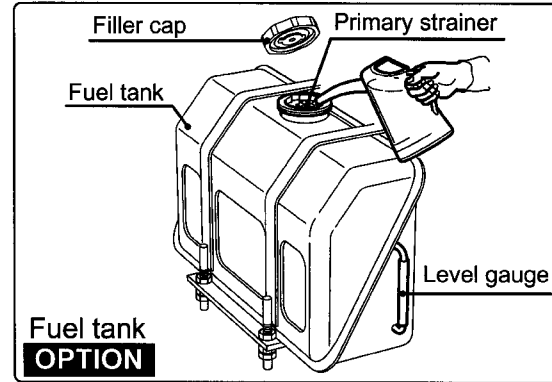

3.2.2 Bleeding the fuel system

Bleed the fuel system according to the following procedures. When there is air in the fuel system, the fuel injection pump will not be able to function.

- 1) Check the fuel oil level in the fuel tank. Refuel if insufficient.
- 2) Open the cock of the oil / water separator.
- 3) Loosen the air bleeding bolt on the oil /water separator by turning 2~3 times to the counter-clockwise using screw driver or spanner.
- 4) When the fuel coming out is clear and not mixed with any bubbles, tighten the air bleeding bolt.
- 5) Feed the fuel with the fuel priming pump or electromagnetic fuel feeding pump.
 - In case of the engine using the electromagnetic fuel feeding pump. **OPTION**
Turn the starter switch to the ON position and hold it in the position for 10~15 seconds to operate the fuel feeding pump.
 - In case of the engine installed the fuel filter mounting with the fuel priming pump. **OPTION**
Follow steps 1) to 4) of the above and then follow the steps below.
- 6) Loosen the air bleeding bolt on the fuel filter mounting by turning 2~3 times to the counter-clockwise using a screw driver or spanner.

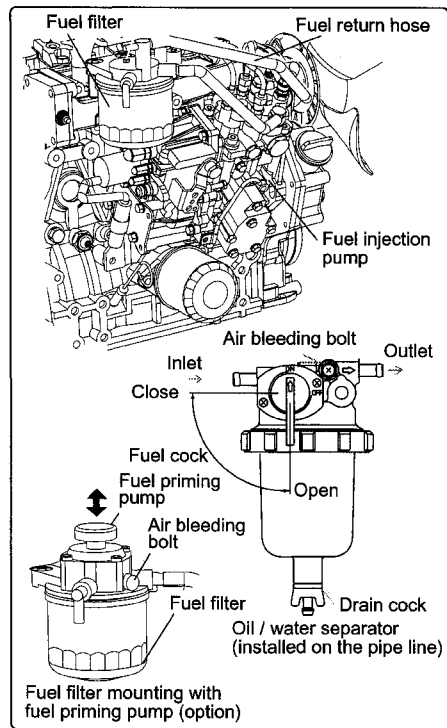

- 7) Move the priming pump up and down to feed fuel until the fuel coming out is not mixed with any bubbles. And then tighten the air bleeding bolt.

3.3 Supplying Engine Oil

(Refer to 3.1.2 Engine oil)

Fill the oil pan with engine oil as specified level.

- 1) When checking or filling / refilling the engine oil, place the machine unit so that the engine is set on a level.
- 2) Remove the filler cap (yellow colored) on the rocker arm cover or on the side of the engine.
- 3) Fill with engine oil up to the upper limit on the dipstick. To check the oil level, insert the dipstick in fully. When checking the engine oil level with the dipstick, wait for about 3 minutes and then check the level as it takes a little while for the engine oil supplied from the filler port to fill the oil pan.
- 4) Manually tighten the filler cap. Do not use a tool such as pliers to tighten it. Excess tightening may cause to damage the filler cap.

IMPORTANT:

Do not overfill the oil pan with engine oil. Overfilling may result in white exhaust smoke, sudden over engine speed or engine internal damage, getting engine oil into the intake port. Be sure to keep the specified level between upper limit and lower limit on the dipstick.

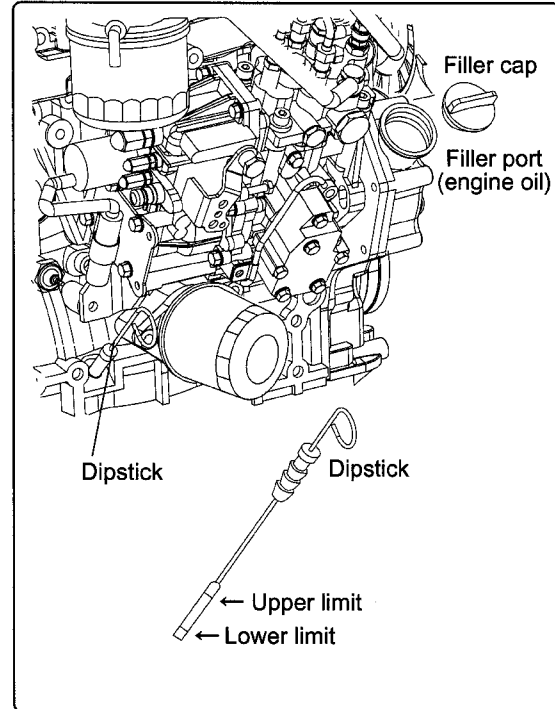

Engine oil capacity (oil pan) (L)	
3CD1, 3CD1T, 3CE1	6.7
3CC1	5.5

NOTICE:

Engine oil capacity may differ from the above depending on the engine installed on the machine unit.

Refer to the instruction manual provided by the equipment manufacturer.

3.4 Supplying Cooling Water

⚠ DANGER



(Refer to 3.1.3. Cooling water)

- Never open the radiator filler cap while the engine and radiator are still hot. Steam and hot water will spurt out and seriously burn you. Wait until the radiator is cooled down after the engine has stopped, wrap the filler cap with a rag piece and turn the cap slowly to gently release the pressure inside the radiator.
- Securely tighten the filler cap after checking the radiator. Steam can spurt out during operation, if the cap is tightened loosely.

Fill the radiator and sub-tank with the cooling water as following procedures.

- 1) Before filling, check to be sure the drain plug is closed.
- 2) Remove the radiator cap of the radiator by turning the radiator cap counter-clockwise about 1/3 of a turn.
- 3) Pour the cooling water slowly into the radiator up to the lip of the filler port so that air bubbles do not develop.
- 4) After supplying the cooling water, surely tighten the radiator cap. To fasten the radiator cap, align the claws on the back face of the radiator cap with the notches of the filler port and press-turn the cap clockwise approx. 1/3 of a turn until contact with each other.
- 5) Remove the cap of the sub-tank, supply the cooling water to the FULL mark and fasten the cap.
- 6) Check the rubber hose connecting the sub-tank to the radiator. Be sure the rubber is securely connected and there is no looseness or damage. When the rubber hose is not water tight, an excessive amount of cooling water will be consumed.
- 7) When filling with the cooling water for the first time or replacing, the cooling water will enclose the air into the cooling water system. So, as the air in the cooling water system is made to bleed automatically during engine operation, the cooling water level in the radiator and sub-tank will be lowered. Replenish the cooling water into the radiator and sub-tank until it reaches the FULL mark of the sub-tank.

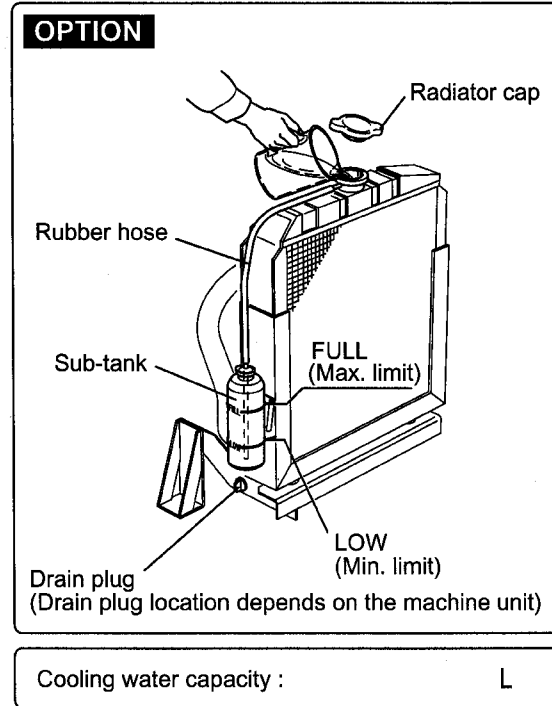

3. BEFORE OPERATION ——— 42

- Daily check of the cooling water level and refilling can be done by observing the sub-tank. **OPTION**
Refer to 4.1(4)
- The cooling water capacity of the radiator **OPTION** depends on the machine unit.
Refer to the instruction manual provided by the equipment manufacturer. And write down the cooling water capacity above right blank to remember.
- Check the cooling water level when the engine is cold. Radiator cooling water flows to the sub-tank when the radiator is still hot and makes accurate checks impossible.
- Check radiator and hoses for leakage.

3.5 Checking the Engine Oil and Cooling Water

When engine oil or cooling water is supplied for the first time or replaced, run the engine for a while and check the oil and water levels again.

The apparent levels go down because of being distributed to the engine oil passages and self-bleeding air in the cooling water system.

Refill with engine oil and cooling water until they reach the specified level.

(When checking the engine oil again after engine running, wait for about 10 minutes and then check the level as it takes a while for engine oil adhered to the engine internal parts to return to the oil pan.)

- For refilling with engine oil, refer to section 3.3.
- For refilling with cooling water, refer to section 3.4.

4. OPERATION INSTRUCTIONS

This section describes the procedures for starting, adjusting the speed and stopping the engine and the preparation before keeping the engine in storage for a long time.

WARNING

Never operate the engine while you are under the influence of alcohol

- Also, never operate the engine when you are ill or feel unwell as this results in unexpected accidents.

CAUTION



Safe work clothing

- Appropriate safety wear (gloves, special shoes / boots, eye / ear protection, head gear, harness' clothing, etc.) should be used / worn to match the task at hand. Avoid wearing jewelry, unbuttoned cuffs, ties or loose fitting clothes around moving machinery. A serious accident may occur if caught in moving / rotating machinery.
- Do not operate the engine and machine unit wearing earphone or headphone to listen to music or radio. A serious accident may occur because it is difficult to hear a warning from outside.

⚠ WARNING



Preventing exhaust fumes inhalation

- Never block up windows, ventilation ports, or other ventilation equipment such as ventilators of the engine room. Ensure good ventilation during engine operation. Inhaling the exhaust fumes is harmful.
- Never operate the engine in a closed room, tunnel, underground room, manhole or ship's hold. It is dangerous since exhaust fumes cannot get out.

⚠ WARNING



Keep away from moving / rotating parts

- Pay sufficient attention so as not to touch moving rotating parts, or bring your hands or part of your body or clothes close to moving / rotating parts while the engine is running.
Otherwise, you may get injured by being caught by the cooling fan, fly-wheel or PTO shaft. Never operate the engine without covers on the moving / rotating parts. Also, always keep kids and pets away from the engine (machine unit).
- Check before starting the engine to see that any tools or cloths used in the maintenance have been removed from the area.

⚠ CAUTION



Preventing burn from contacting with hot surface

- Pay sufficient attention not to bring part of your hand and body or clothes in contact with the silencer, exhaust pipe, turbocharger and engine body during operation or shortly after stopping the engine.

The whole engine is hot and scalding / serious burns may result.

- Carry out cooling down engine running for 5 minutes without load before the engine has been stopped. Sudden shutting the engine down without any cooling down running causes the engine and around temperature to rise rapidly. Scalding / serious burns or fires may result.

4.1 Check before Daily Operation

Be sure to check the following points before starting the engine every day.

(1) Visual check around engine. If any problem is found, do not use before the engine repairs have been completed.

- Oil leak from the lubrication system
- Fuel leak from the fuel system
- Cooling water leak from the cooling water system
- Damaged parts
- Loosened or lost bolts
- Fuel, radiator rubber hoses cracked, loosened clamp

(2) Checking and refueling

Check the remaining fuel oil level in the fuel tank and refuel the recommended fuel if necessary.

(3) Checking and replenishing engine oil

- 1) Check the engine oil level with the dipstick.
- 2) If the remaining engine oil level is low, replenish the specified engine oil to the specified level through the filler port. Replenish the oil to the upper limit mark while checking the level with the dipstick gauge. See 3.3

(4) Checking and replenishing cooling water

⚠ DANGER



Burns from scalding

- Never open the radiator filler cap while the engine and radiator are still hot. Steam and hot water will spurt out and seriously burn you. Wait until the radiator is cooled down after the engine has stopped, wrap the filler cap with a rag piece and turn the cap slowly to gently release the pressure inside the radiator.
 - Securely tighten the filler cap after checking the radiator. Steam can spurt out during operation, if the cap is tightened loosely.
- 1) Check the cooling water level in the sub-tank. If the water level is close to the LOW mark, open the sub-tank cap and replenish clean soft water to the FULL mark.
 - 2) If the sub-tank water level is lower than the LOW mark, open the radiator cap and check the cooling water level in the radiator. Replenish the cooling water into the radiator and sub-tank if the level is low. Refer to 3.4
 - Check the cooling water level while the engine is cool. Checking when the engine is hot is dangerous. And the water volume is expanded due to the heat.
 - Daily cooling water level check and replenishing shall be done only at the sub-tank. If the cooling water is close to the LOW mark, open the sub-tank cap and replenish only clean soft water to the FULL mark. Usually do not open the radiator cap to check or replenish.

IMPORTANT:

If the cooling water runs short quickly or when the radiator runs short of water with the sub-tank level unchanged, water may be leaking or the air tightness may be lost. In such case, please contact your dealer.

Increase in the sub-tank water level during operation is not abnormal.

The increased water in the sub-tank returns to the radiator when the engine is cooled down.

(5) Checking accelerator operation

Make sure the accelerator of the machine unit can be operated smoothly before starting the engine. If it feels heavy to manipulate, lubricate the accelerator cable joints and pivots. Adjust the accelerator cable if there is a dislocation or excessive play between the accelerator and the governor lever. Refer to 5.3.3(3)

(6) Checking alarm operation

Before and after starting the engine, check to see the alarm function normally. Failure of alarm cannot warn the lack of the engine oil or the cooling water. Make it a rule to check the alarm operation before and after starting engine every day. Refer to 4.2

4.2 Checking the Control Panel and Alarm Devices

Be sure to check the alarm devices and other instruments on the panel before and after starting the engine. If the devices are not working properly, it is impossible to prevent any problems arising from insufficient oil and water in the engine. Make checking the alarm and other devices before and after starting a regular practice.

4.2.1 Checking alarm lamps

- 1) Insert the key into the starter switch.
- 2) Turning the key to the ON position, the alarm devices function as follows.
 - Battery charge alarm lamp comes on.
 - Engine oil press. alarm lamp comes on.
 - Cooling water temp. alarm lamp does not come on.

When the lamps function as above, everything is normal.
- 3) When the key is turned to the START position to start the engine and then returned to the ON position after the engine starting up, the alarm devices function as follows.

All alarm lamps go off. After the engine starts up make it the rule to check alarm devices. If they do not work normally, contact your dealer.

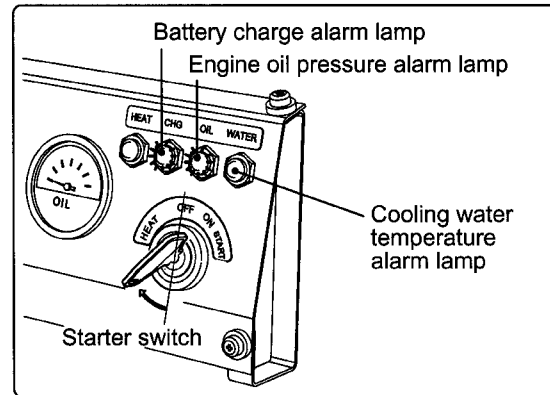

4. OPERATION INSTRUCTIONS — 52

Function of alarm devices		
Alarm lamps	Key operation	
	OFF → ON	START → ON
Battery charge alarm lamp	ON	OFF
Engine oil pressure alarm lamp	ON	OFF
Cooling water temperature alarm lamp	OFF	OFF

4.2.2 Checking the instruments (meters)

Before starting the engine, the needles of the meters are on the left side end. After starting the engine, the needles indicate the engine running conditions. Check the engine running conditions.

Ⓐ Tachometer

The needle indicates the engine speed in response to the running speed.

Ⓑ Cooling water temperature meter

The needle indicates the cooling water temperature.

Ⓒ Engine oil pressure meter

The needle indicates the engine oil pressure.

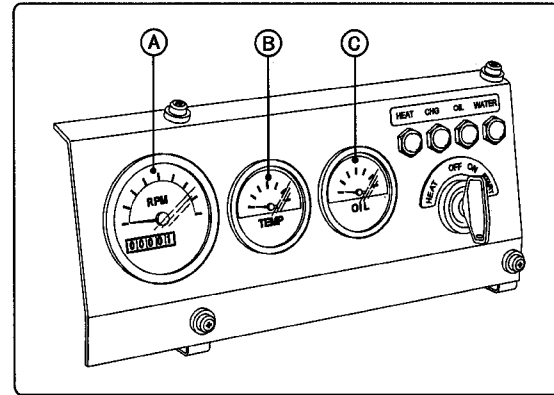

4.3 Starting

⚠ DANGER



Preventing fire

- Start the engine only from a starter switch without any load or in neutral position of the clutch of machine unit. Starting by means of connecting with the terminals of starter motor using a screwdriver or the like (jumping start) may cause fire due to spark at the terminals of starter motor. Also, the machine unit suddenly starts to move or generates power to cause serious personal injury.

⚠ WARNING



Keep away from moving / rotating parts

- Check before starting the engine to see that any tools or cloths used in the maintenance has been removed from the area.
- Pay sufficient attention so as not to touch moving / rotating parts, or bring your hands or part of your body or clothes close to moving / rotating parts while the engine is running.

Otherwise, you may get injured by being caught by the cooling fan, fly-wheel or PTO shaft. Never operate the engine without covers on the moving / rotating parts. Also, keep kids and pets away from the engine (machine unit).

4.3.1 Daily starting the engine procedure

Start the engine as shown below.

- 1) Place in neutral position of the clutch or turn the main switch OFF to release the load on machine unit.
- 2) Open the cocks of the oil / water separator and fuel tank.
- 3) Insert the key into the starter switch.
- 4) Turn the key from the OFF to the ON position. Check all alarms are normal. Refer to 4.2.1
- 5) Set the accelerator (Governor lever) on the middle speed position.
- 6) Turn the key to the START position to start the engine. Release the key as soon as the engine starts. The key automatically returns to the ON position. If the engine does not start, turn the key to the OFF position first before trying to start again.

IMPORTANT:

Do not hold the key at the START position for more than 15 seconds at a time. Any longer attempt will overheat the starter motor.

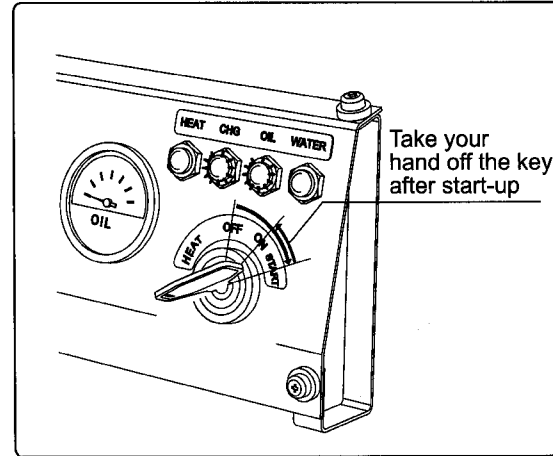

4.3.2 Warming up running

After the engine has started, make sure to run for 5 minutes at an even low engine speed and without any load. On load running while the engine is cold causes to emit black exhaust smoke and shortens engine life as this engine has the device automatically adjusting the fuel injection quantity and timing by detecting the cooling water temperature. While warming up running, check the engine for any abnormal sound.

IMPORTANT:

Do not race the engine while it is cold.

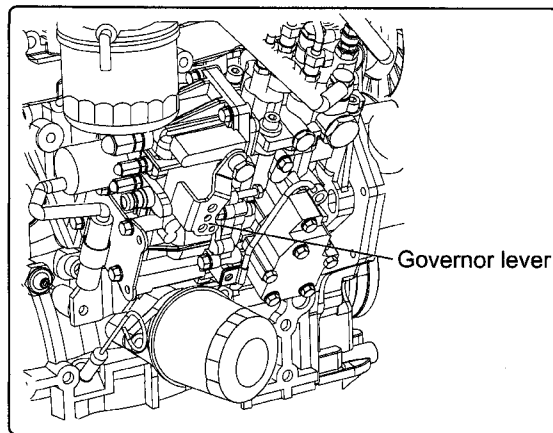

4.3.3 Starting up the engine at low ambient temperature

If the engine is hard to start in cold weather (approx. 0°C or below), use the air heater **OPTION** for easier starting. Follow steps 1) to 4) of the previous mentioned procedure and then follow the steps below.

- 7) Set the accelerator on the maximum speed position.
- 8) Turning the key from the OFF to the HEAT position, the HEAT lamp (blue colored) **OPTION** comes on. Keep the key in the HEAT position while the lamp is lighting.
- 9) When the air heater is heated up after about 15 seconds, the lamp goes off to turn the key to the START position. Remove your hand from the key as soon as the engine starts, and the key returns to the ON position by itself.

IMPORTANT:

- *Do not leave the air heater on for longer than 20 seconds at a time. Leaving the air heater on for longer periods of time will result in damage.*
- *Never use a engine start aiding liquid such as gasoline, ether. They will result in engine damage.*

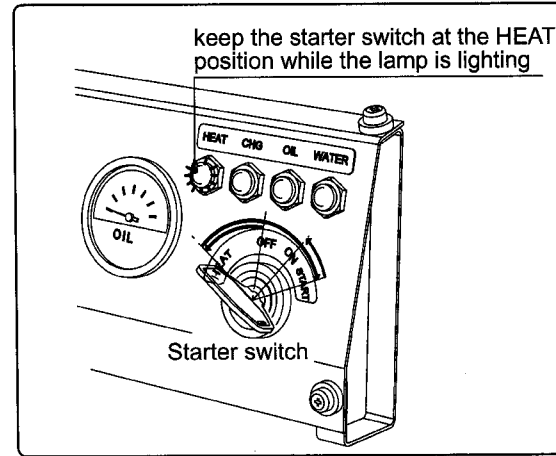

4.3.4 Restarting after starting failure

When attempting to restart the engine after starting failure, be sure that the engine is at a complete stop before turning the key.

IMPORTANT:

- *Do not turn the key to the START position when the engine is not completely stopped or during operation. Otherwise, the starter motor pinion or ring gear will be damaged.*
- *Wait at least 30 seconds before the second attempt to allow for battery voltage recovery.*

4.3.5 After the engine has started

After the engine has started, warm up the engine (refer to 4.3.2) and check the following points. If any abnormality, stop the engine and contact your dealer.

- Alarm lamps and instruments
- Water leak and oil leak from engine
- Color of exhaust gas
- Vibration or noise

4.4 Adjusting the Engine Speed

The engine speed is controlled by the governor lever. It is linked with the accelerator system on the machine unit side (accelerator handle and pedal to be procured by the equipment manufacturer) by means of an accelerator wire for remote control.

IMPORTANT:

For a new engine, be especially careful not to change engine speed abruptly or attach a heavy load for the first 50 hours of operation. Failure to do so may result in damage and shorten the life of the engine.

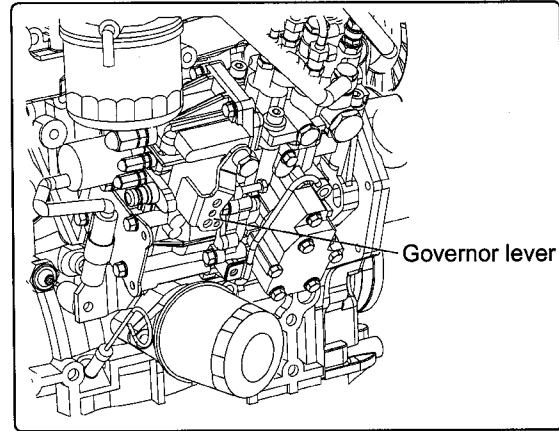

4.5 Check during Operation

Watch the following points to check the engine conditions.

- Exhaust gas color

Avoid engine operation if black smoke continues to come out. Black smoke is generated when the engine is overloaded. This shortens the engine life.

- Abnormal noise or vibration

Depending on the machine unit structure, resonance may arise at a certain engine speed, resulting in sudden violent vibration. Avoid engine operation near that speed.

- Alarm lamps

If an alarm lamp comes on, do not be flurried but decrease the engine speed and remove the load on the engine. Then, stop the engine, check the cause and take the necessary action.

- Water, oil or gas leakage, or loosened bolts

Occasionally check the engine and its peripheral parts for any symptom of leakage or loosened bolt.

- Low fuel level in tank

Always replenish fuel before the level drops too low during operation.

IMPORTANT:

- *Allowable inclined engine operation : 25 deg. max. (both tossed and rolled side)*

Excess inclined engine operation may result in white exhaust smoke, sudden over engine speed or engine internal damage, getting engine oil into the intake port. Operate the engine on a place as level as possible.

- *Avoid low load running as much as possible. When operating at low load, operate at 1/4 load or greater. If it continues for a long time, carbon will mix in with the unburned fuel depositing the piston head, injection nozzle and exhaust pipe to cause engine trouble.*
- *Do not turn the key to the START position while engine running. Otherwise, the starter motor pinion or ring gear will be damaged.*

4.6 Stopping the Engine

CAUTION



- Pay sufficient attention not to bring part of your hand and body or clothes in contact with the silencer, exhaust pipe, turbocharger and engine body during operation or shortly after stopping the engine. The whole engine is hot and may cause scalding / serious burns.
- Carry out the cool-down running for 5 minutes without load before the engine has been stopped. Suddenly shutting the engine down without any cool-down running causes the engine and around temperature to rise rapidly. Scalding / serious burns or fires may result.

Stop the engine in accordance with the following procedures.

- 1) Remove the load on the engine by disengaging the clutch or turning the main switch off.
- 2) Set the accelerator (governor lever) to the LOW speed position and carry out cool-down running for 5 minutes.
- 3) Turn the key to the OFF position to stop the engine. Remove the key from the starter switch and place it in a safe place.
- 4) Close the cock of the fuel tank.

IMPORTANT:

- *If the engine is stopped immediately after removing load, the temperature of engine parts will rise suddenly, and this could cause engine trouble.
Always operate the engine without load at low speed for 5 minutes.*
- *When letting the engine (machine unit) leave in open air after operating, place on the level kept away from flammable material such as straws, withered grass as this could result in ignition. And after cooling the engine (machine unit) thoroughly, cover it with airtight plastic covers to protect the air cleaner, silencer and electrical parts (alternator, starter motor, switches, etc.) from water and dust.*

4.7 Taking Care during Long-term Storage

When the engine is to be stored for a long time (3 months or more), take the following care for the next use.

4.7.1 Inspection and maintenance during long-term storage

(1) Periodic check

If the next periodic check is drawing near, carry out the inspection before storage.

(2) Cooling water

Be sure to be clean soft water added Long Life Coolant Antifreeze (LLC) in the cooling water system and do not drain the cooling water added LLC before long-term storage.

If drain the cooling water, it will cause to built up rust due to the residual water in the cooling water system.

(3) Exterior cleaning, fuel oil draining and greasing

- Clean the outside of the engine wiping off any dust or oil.
- To prevent condensation of moisture inside the fuel tank, either drain off the fuel oil or fill the tank with fuel oil.
- Grease the exposed area and joints of the accelerator system.

(4) Water - and dust - proofing

- Protect the air cleaner, silencer and electrical parts (alternator, starter motor, switches) from water and dust with airtight plastic covers.
- Store the engine at a well ventilated place not subject to high moisture or dust.

(5) To prevent the battery self-discharging

- Disconnect the negative terminal (-) of the battery during storage.
- To refill self-discharge from the battery, charge the battery at least once a month during storage.

4.7.2 Checking the engine for reuse after long storage period

When using the engine after a long period of storage, prepare for operation in the same manner as for a new engine. And warm up the engine to distribute the engine oil to all of the parts in the same manner as for daily start the engine. Refer to 3. BEFORE OPERATION, 4. OPERATION INSTRUCTIONS.

⚠ WARNING



*Never run the engine in poorly ventilated room storing it.
Inhalation of exhaust fumes may be hazardous ones health and may cause a
fire hazard.*

5. MAINTENANCE

5.1 Precaution for Inspection

Be sure to perform periodic checks.

The engine deterioration and degradation proceed in proportion to its service conditions and service hours. Leaving deterioration and degradation may cause an unexpected malfunction which interferes with your work an increase in consumption of the fuel and engine oil, or an increase in exhaust gas problems or noise, and result in shortening the life of the engine. Perform routine periodic checks and maintenance to prevent accidents from occurring. Also, perform the checks at a spacious and level place and free from traffic.

Never fail to start-up inspection.

Routine periodic checks are based on start-up inspections. Make a habit of performing the start-up inspections before initial start up for the day. Refer to the section 4.1 Check before Daily Operation.

Keep a record of daily operation to perform the periodic checks.

Keep a record of daily operation and the results of maintenance work. Periodic check intervals are established every 50, 250, 500, 1000 and 2000 service hours. Be sure to perform a periodic check after each set-up interval.

Always use genuine Isuzu parts.

Always use genuine Isuzu parts when replacing consumables. The use of replacement parts which are not genuine may degrade the engine performance or shorten its life.

Have a set of maintenance tool always ready.

Have a set of maintenance tool always ready for checking the machinery.

Ask for our help with periodic checks and maintenance work.

Our professional engineers with good expertise and skills will help you with maintenance, inspection and servicing. Consult your dealer.

Tightening torque for bolts and nuts

Applying excessive tightening torque to a bolt or nut may loosen or damage a tightened part, and too small tightening torque may cause a oil leak from the mounting surface or a loose bolt, which leads to component failure. On essential parts, bolts and nuts should be tightened with an accurate tightening torque using a torque wrench in a correct way and correct order.

When removing parts is required for maintenance, consult your dealer.

The followings are the standard tightening torque for standard bolts and nuts.

IMPORTANT:

The tightening torque described below should be applied only to the bolts with "7" on their head. (JIS strength classification: 7T)

- Apply 60% tightening torque for the bolts which do not appear here.
- Apply 80% tightening torque when tightened to aluminum alloy.



Thread size × Pitch mm	M6×1.0	M8×1.25	M10×1.5	M12×1.75	M14×1.5	M16×1.5
Tightening torque N•m (kgf•m)	10.8±1.0 (1.1±0.1)	25.5±2.9 (2.6±0.3)	49.0±4.9 (5.0±0.5)	88.3±9.8 (9.0±1.0)	137±9.8 (14.0±1.5)	226±9.8 (23.0±2.0)

5.2 List of Periodic Inspections

Daily and periodic inspections are important to keep the engine in its best condition. The following is a summary of inspection and servicing items by inspection interval. Periodic inspection intervals vary depending on the use, loads, fuels and engine oils used and handling conditions, and are hard to establish definitively. The following should be treated only as a general standard.

IMPORTANT:

Establish a periodic check plan according to the operating conditions and make sure to conduct checks at specified intervals. Otherwise, malfunctioning may occur to shorten the engine life.

As special knowledge and skill are required for items marked with ●, consult your dealer or Isuzu distributor.

○: Check ◇: Replace ●: Contact your dealer

System	Check item	Daily	Periodic inspection interval				
			Every 50 hours	Every 250 hours	Every 500 hours	Every 1000 hours	Every 2000 hours
Fuel oil	Fuel tank oil level check and refill	○					
	Draining from fuel tank		○				
	Draining from oil / water separator		○				
	Cleaning oil / water separator				○		
	Fuel filter replacement				◇		

5. MAINTENANCE ——— 70

System	Check item	Daily	Periodic inspection interval				
			Every 50 hours	Every 250 hours	Every 500 hours	Every 1000 hours	Every 2000 hours
Engine oil	Engine oil level	○					
	Engine oil replacement		◇	◇			
	Engine oil filter replacement		1st time	2nd & after			
Cooling water	Check & addition cooling water	○					
	Radiator fin checking & cleaning			○			
	Cooling fan V-belt checking & adjusting		○ 1st time	○ 2nd & after			
	Cooling water replacement				◇ or every 1 yr.		
	Cooling water path flushing & maintenance						●
Rubber hoses	Fuel & cooling water pipe replacement						● or every 2 yrs.
Operating system	Governor lever & accelerator check & adjust	○		○			
Intake & exhaust	Air cleaner element cleaning & replacement			○	◇		
	Turbocharger blower washing *					●	
Electrical equipment	Alarm operation check	○					
	Battery electrolyte check & recharging		○				
Cylinder head	Adjust intake / exhaust valve clearance					●	
	Lapping intake / exhaust valve seats						●

System	Check item	Daily	Periodic inspection interval				
			Every 50 hours	Every 250 hours	Every 500 hours	Every 1000 hours	Every 2000 hours
Fuel valve, pump *	Check fuel injection valve pressure & adjust					●	
	Check & adjust fuel injection pump						●

*The specific emissions related parts for the EPA/ARB regulations.

EPA allows to apply Maintenance schedule for Emission related parts as follows.

—	Check Fuel Valve Nozzle and clean	Adjust, cleaning and repair of Fuel injection Pump and Fuel Valve Nozzle
kW ≤ 130	1500 hours of use and at 1500-hour intervals thereafter	3000 hours of use and at 3000-hour intervals thereafter

5.3 Periodic Inspection Items

5.3.1 Inspection after initial 50 hours operation

(1) Replacing the engine oil and engine oil filter (1st time)

 CAUTION



When the engine oil is still hot, be careful with a splash of engine oil which may cause burns. Cool the engine to replace engine oil until the engine oil becomes warm. It is most effective to drain the engine oil while the engine is still warm.

In early period of use, the engine oil gets dirty rapidly because of the initial wear of internal parts. Replace the engine oil earlier.

Engine oil filter should also be replaced when the engine oil is replaced.

Engine oil and engine oil filter replacing procedures are as follows.

Remove the oil filler cap to drain easily while draining the engine oil.

- 1) Prepare a waste oil container collecting waste oil.
 - 2) Loosen the drain plug using a wrench (customer procured) to drain the engine oil.
 - 3) Securely tighten the drain plug after draining the engine oil.
 - 4) Turn the engine oil filter counter-clockwise using a filter wrench (customer procured) to remove it.
 - 5) Clean the engine oil filter mounting face.
 - 6) Moisten the new engine oil filter gasket with the engine oil and install the new engine oil filter manually turning it clockwise until it comes into contact with the mounting surface, and tighten it further to 3/4 of a turn with the filter wrench.
- Tightening torque: 20~24N•m (2.0~2.4kgf•m)

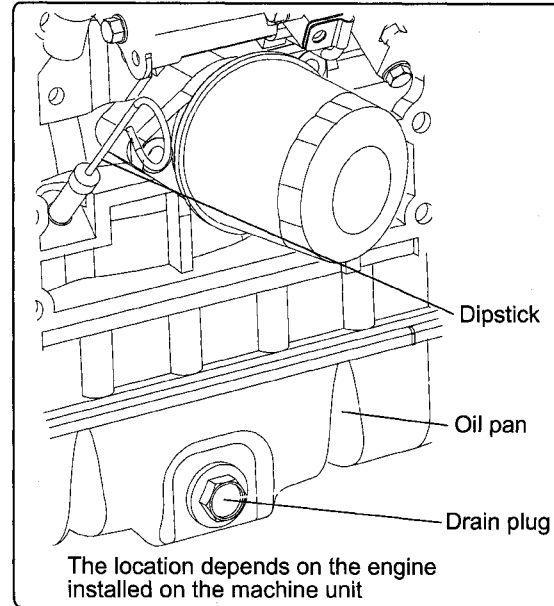

5. MAINTENANCE — 74

- 7) Fill with the new engine oil until it reaches the specified level as explained in section 3.3.

IMPORTANT:

Do not overfill the oil pan with engine oil.

Be sure to keep the specified level between upper and lower limit on the dipstick.

- 8) Warm up the engine by running for 5 minutes while checking any oil leakage. (Refer to 4.3.2 Warming up running)
- 9) Stop the engine after warming up and leave it stopping for about 10 minute to recheck the engine oil level with dipstick and replenish the engine oil. If any oil is spilled, wipe it away with a clean cloth.

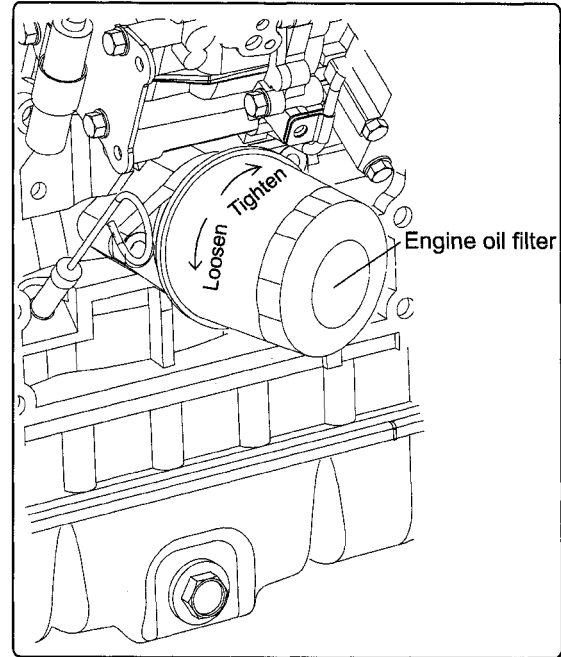

(2) Checking and adjusting cooling fan V-belt

When there is not enough tension in the V-belt, the V-belt will slip making it impossible for the alternator to generate power and cooling water pump and cooling fan will not work causing the engine to overheat.

Check and adjust the V-belt tension (deflection) in the following manner.

- 1) Press the V-belt down with your thumb [approx. 98N(10kgf)] at the middle of the V-belt span to check the tension (deflection).

Available positions to check and adjust the V-belt tension (deflection) are at the A, B and C showing with the arrow direction as shown illustration right.

You may choose a position whichever you can most easily carry out the check and adjustment on the machine unit.

The specified deflection to be measured at each position should be as follows.

A	B	C
10~14 mm	7~10 mm	9~13 mm

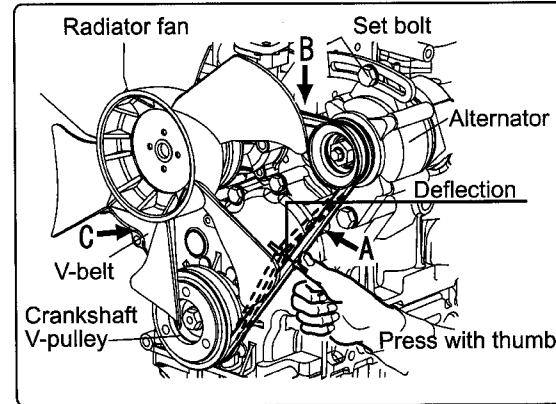

- 2) If necessary, adjust the V-belt tension (deflection). To adjust the V-belt tension, loosen the set bolt and move the alternator to tighten the V-belt.
- 3) Visually check the V-belt for cracks, oiliness or wear. If any, replace the V-belt with new one.
 - "New V-belt" refers to a V-belt which has been used less than 5 minutes on a running engine.
 - "Used V-belt" refers to a V-belt which has been used on a running engine for 5 minutes or more.

Install the new V-belt adjusting the deflection to the value in the table below according to the above manner. After adjusting, run the engine for 5 minutes and readjust the deflection to the value in the table above.

A	B	C
8~12 mm	5~8 mm	7~11 mm

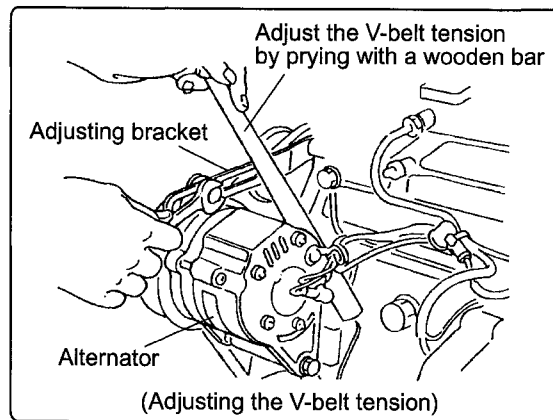

5.3.2 Inspection every 50 hours operation

(1) Draining of the fuel tank

- 1) Prepare a waste oil container.
- 2) Loosen the drain plug of the fuel tank to drain (water, dust, etc.) from the fuel tank bottom.
- 3) Drain until fuel with no water and dust flow out. Then tighten the drain plug firmly.

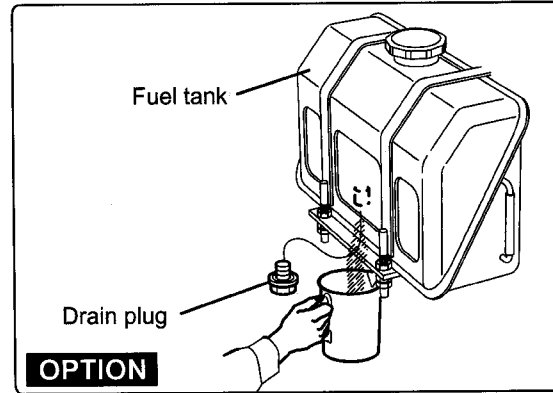

(2) Draining of the oil/water separator

Drain off the oil/water separator whenever there is a lot of drain collected in the oil/water separator at the bottom of the cup even if not the time for periodic inspection hour. The cup of the oil/water separator is made from semi-transparency material and in the cup, the red colored float ring which rises on the surface of the drain is installed to visualize the amoun of drain. Also, the oil/water separator with sensor to detect the drain for warning device on a controle panel is provided as the optional.

Drain off the oil/water separator in the following manner.

- 1) Prepare a waste oil container.
- 2) Close the fuel cock.
- 3) Loosen the drain cock at the bottom of the oil/water separator, and drain off any water collected inside.
- 4) Tighten the drain cock with hand.
- 5) Be sure to bleed air in the fuel system.
Refer to 3.2.2

NOTE:

If no drain drips when the drain cock is opened, loosen the air bleeding bolt on the top of the oil/water separator by turning counter-clockwise 2~3 times using screw driver.

(This may occur in case of the oil/water separator position is higher than the fuel oil level in the fuel tank). After draining, be sure to tighten the air bleeding bolt.

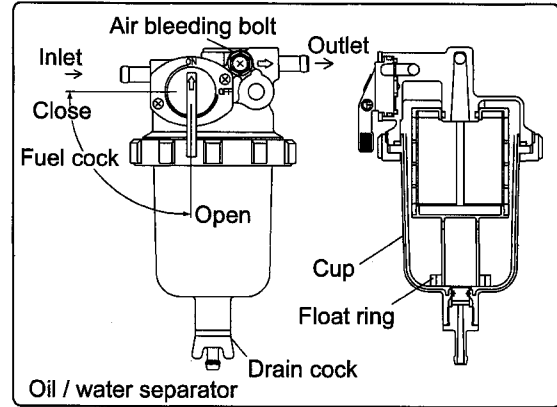

(3) Inspection of battery

▲ WARNING**Fire due to electric short-circuit**

- Make sure to turn off the battery switch or disconnect the negative cable (-) before inspecting the electrical system. Failure to do so could cause short-circuiting and fires.
- Always disconnect the (-) Negative battery cable first before disconnecting the battery cables from battery. An accidental "Short circuit" may cause damage, fire and or personnel injury.
And remember to connect the (-) Negative battery cable (back onto the battery) LAST.

**Proper ventilation of the battery area**

Keep the area around the battery well ventilated, paying attention to keep away any fire source. During operation or charging, hydrogen gas is generated from the battery and can be easily ignited.

**Do not come in contact with battery electrolyte**

Pay sufficient attention to avoid your eyes or skin from being in contact with the fluid. The battery electrolyte is dilute sulfuric acid and causes burns. Wash it off immediately with a large amount of fresh water if you get any on you.

5. MAINTENANCE — 80

- Check the level of fluid in the battery.
When the amount of fluid nears the lower limit, fill with battery fluid (available in the market) to the upper limit. If operation continues with insufficient battery fluid, the battery life is shortened, and the battery may overheat and explode.
- Battery fluid tends to evaporate more quickly in the summer, and the fluid level should be checked earlier than the specified times.
- If the engine cranking speed is so slow that the engine does not start up, recharge the battery.
- If the engine still will not start after charging, replace the battery.
- Remove the battery from the battery mounting of the machine unit after daily use if letting the machine unit leave in the place that the ambient temperature could drop at -15°C or less. And store the battery in a warm place until the next use the unit to start the engine easily at low ambient temperature.

OPTION

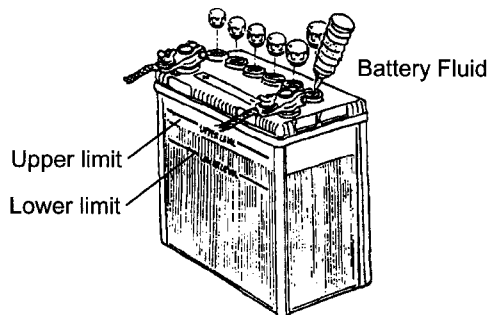

Follow the instructions and precautions in the manual from the battery maker.

5.3.3 Inspection every 250 hours operation

(1) Replacing the engine oil and engine oil filter (2nd time and after)

Replace the engine oil every 250 hours operation from 2nd time and on. Replace the engine oil filter at the same time. Refer to 5.3.1(1).

(2) Checking and cleaning radiator fins.

⚠ CAUTION

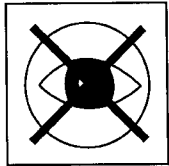

Beware of dirt from air blowing

Wear protective equipment such as goggles to protect your eyes when blowing compressed air. Dust or flying debris can hurt eyes.

Dirt and dust adhering on the radiator fins reduce the cooling performance, causing overheating. Make it a rule to check the radiator fins daily and clean as needed.

- Blow off dirt and dust from fins and periphery with compressed air [0.19MPa (2kgf/cm²) or less] not to damage the fins with compressed air.
- If contaminated heavily, apply detergent, thoroughly clean and rinse with tap water shower.

IMPORTANT:

Never use high pressure water or air from close by fins or never attempt to clean using a wire brush. Radiator fins can be damaged.

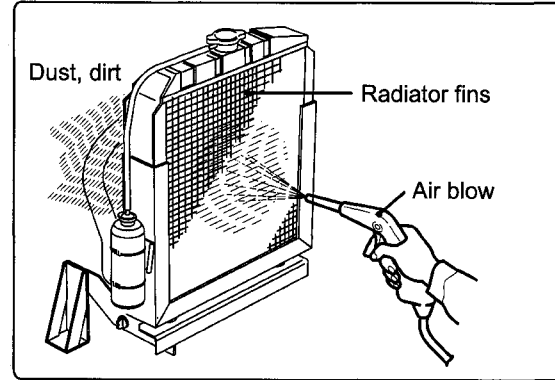

(3) Checking and adjusting the governor lever and accelerating device

The governor lever and accelerating devices (accelerating lever, pedal, etc.) of the machine unit are connected by an accelerating wire or rod. If the wire becomes stretched or the connections loosen, the deviation in the position may result and make operation unsafe. Check the wire periodically and adjust if necessary. Consult your dealer for the adjustment. Do not strongly move the accelerating wire or accelerating pedal. It may deform the governor lever or stretch the wire to cause irregular engine speed control.

Checking and adjusting procedures are as follows.

- 1) Check that the governor lever of the engine makes uniform contact with the high idling and low idling limiting bolt when the accelerating devices is in the high idling speed or low idling speed position.
- 2) If either the high or the low idling speed side does not make contact with the limiting bolt, adjust the accelerating wire.

Loosen the accelerating wire fixing nut and adjust the wire to contact with the limiting bolt.

IMPORTANT:

Never release the limiting bolts. It will impair the safety and performance of the product and functions and result in shorter engine life.

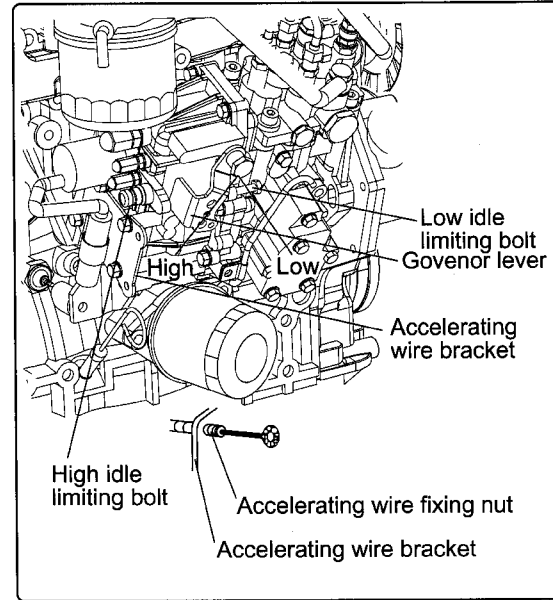

(4) Air cleaner element cleaning

⚠ CAUTION

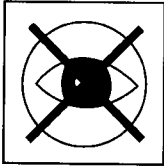

Beware of dirt from air blowing

Wear protective equipment such as goggles to protect your eyes when blowing compressed air. Dust or flying debris can hurt eyes.

The engine performance is adversely affected when the air cleaner element is clogged by dust. So periodical cleaning after disassembly is needed.

- 1) Undo the latches on the dust pan and remove the dust pan.
- 2) And then pull out the element.

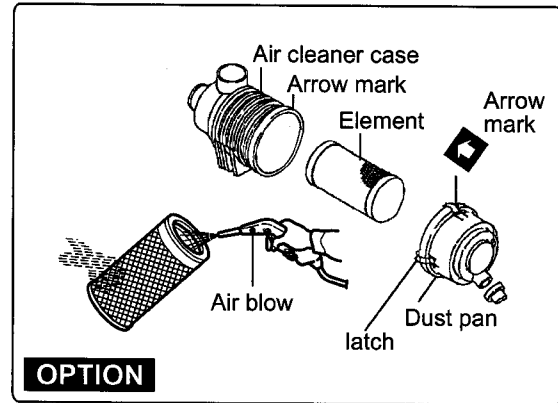

- 3) Blow air [0.29~0.49MPa (3.0~5.0kgf/cm²)] from inside the element to blow dust off as shown the illustration right. Apply the air blowing pressure as low as possible so as not to damage the element. If having the air cleaner with double elements, never remove and clean the inner element. The aim of installing the inner element is for back up protecting from intaking dust during engine running when leaving the outer element to reinstall after removing to clean it or when damaging the outer element unexpectedly during engine running.
- 4) Replace the element with new one if the element is damaged, excessively dirty or oily.
- 5) Clean inside of the dust pan.
- 6) Reinstall the element inserting into the air cleaner case. And install the dust pan to the air cleaner case matching the arrow marks on the dust pan and air cleaner case, then fasten the dust pan with the latches.

IMPORTANT:

- When the engine is operated in dusty conditions, clean the element more frequently.
- Do not run the engine with removed air cleaner or element, as this may cause foreign material to enter and damage the engine.

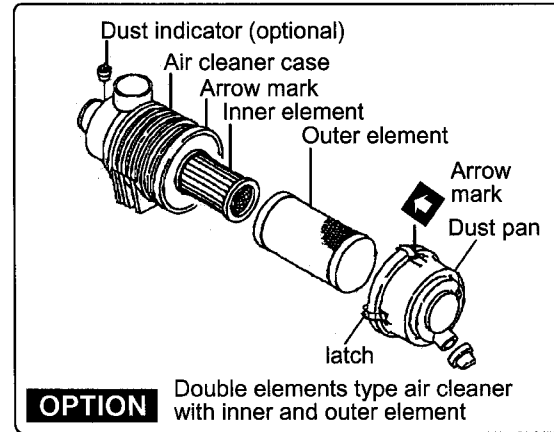

(5) Checking and adjusting cooling fan V-belt (2nd time and after)

Check and adjust the cooling fan V-belt tension every 250 hours operation from 2nd time and on.
Refer 5.3.1(2)

5.3.4 Inspection every 500 hours operation

(1) Replacing the air cleaner element

Replace the air cleaner element periodically even if it is not damaged or dirty.

When replacing the element, clean the inside air cleaner case at the time.

If having the air cleaner with double elements, do not remove the inner element. If the engine output is still not recover (or the dust indicator still actuates if having the air cleaner with a dust indicator) even though the outer element has replaced with new one, replace the inner element with new one.

(2) Replacing fuel filter

Replace the fuel filter at specified intervals before it is clogged with dust to adversely affect the fuel flow. Also, replace the fuel filter after the engine has fully been cooled.

- 1) Close the fuel cock of the oil/water separator.
- 2) Remove the fuel filter using a filter wrench (customer procured). When removing the fuel filter, hold the bottom of the fuel filter with a piece of rag to prevent the fuel oil from dropping. If you spill fuel, wipe such spillage carefully.
- 3) Clean the filter mounting surface and slightly apply fuel oil to the gasket of the new fuel filter.
- 4) Install the new fuel filter manually turning it clockwise until it comes into contact with the mounting surface, and tighten it further to one turn using a filter wrench. Tightening torque: $20\sim 24\text{N}\cdot\text{m}$ ($2.0\sim 2.4\text{kgf}\cdot\text{m}$)
- 5) Bleed the fuel system. Refer to 3.2.2

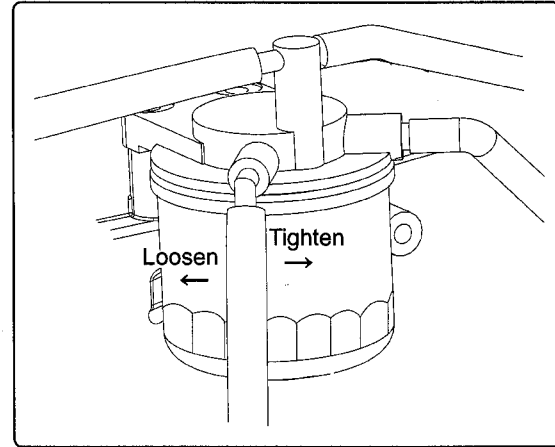

IMPORTANT:

Be sure to use genuine Isuzu part (super fine mesh filter). Otherwise, it results in engine damage, uneven engine performance and shorten engine life.

(3) Cleaning oil/water separator

Periodically wash the oil/water separator element and inside cup with clean fuel oil.

- 1) Prepare a waste oil container.
- 2) Close the fuel cock.
- 3) Loosen the drain cock and drain.
Refer to 5.3.2(2)
- 4) Turn the retaining ring counter-clockwise and remove the cup. (Keep the float ring at hand.)
(Disconnect the coupler of the lead wire for drain sensor before removing the cup if it is with drain sensor).
- 5) Wash the element and inside cup with clean fuel oil. Replace the element with new one if any damaged.
- 6) Insert the element to the bracket (O-ring) and after putting the float ring in the cup, install it to the bracket by tightening the retaining ring clockwise.
Tightening torque: $15\sim 20\text{N}\cdot\text{m}$ ($1.5\sim 2.0\text{kgf}\cdot\text{m}$)
- 7) Close the drain cock (connect the coupler if with drain sensor).
- 8) Bleed the fuel system. Refer to 3.2.2

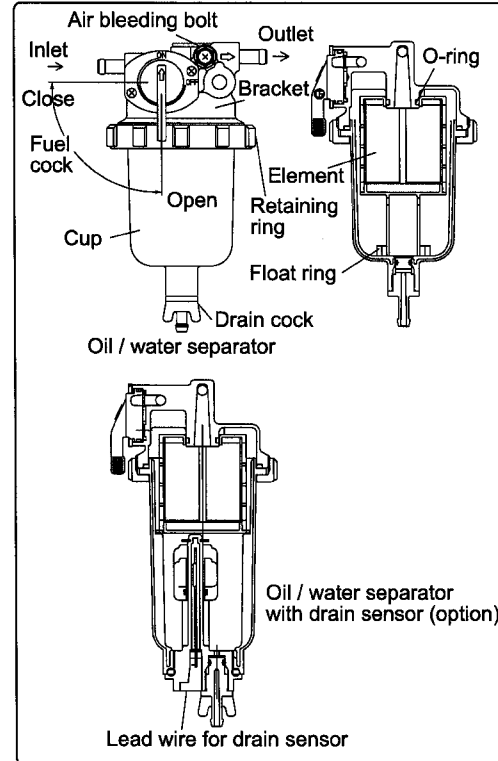

5.3.5 Inspection every 1000 hours operation

(1) Replacing cooling water

Cooling water contaminated with rust or water scale reduces the cooling effect. Even when antifreeze agent (LLC) is mixed, the cooling water gets contaminated due to deteriorated ingredients. Replace the cooling water at least once a year.

- 1) Remove the radiator cap.
- 2) Loosen the drain plug at the lower portion of the radiator and drain the cooling water.
- 3) After draining the cooling water, tighten the drain plug.
- 4) Fill radiator and engine with cooling water. Refer to 3.4

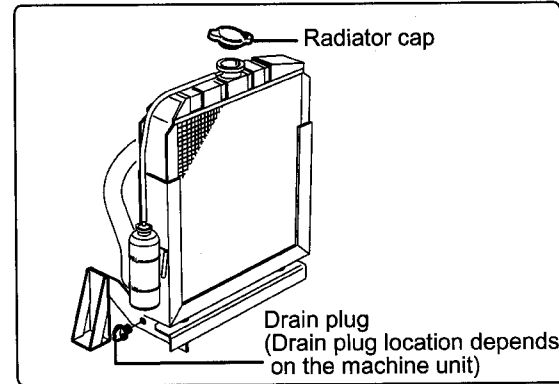

CAUTION



Beware of scalding by hot water

Wait until the temperature goes down before draining the cooling water. Otherwise, hot water may splash to cause scalding.

(2) Washing the turbocharger blower **3CD1T**

As this washing the turbocharger blower requires specialized knowledge. Consult your dealer. When engine speed seems sluggish or the exhaust color poor, the blades of the turbocharger blower may be dirty. Wash the blower.

(3) Checking and adjusting the fuel injection valve

As the adjustment requires specialized knowledge and skill, consult your dealer. This adjustment is needed to obtain the optimum injection pattern for full engine performance.

(4) Adjusting intake / exhaust valve clearance

As this adjustment requires specialized knowledge and skill, consult your dealer. The adjustment is necessary to maintain the correct timing for the opening and closing of valves. Neglecting the adjustment will cause the engine to run noisily and result in poor engine performance and other damage.

5.3.6 Inspection every 2000 hours operation

(1) Flushing the cooling system and checking the cooling system parts

As this maintenance requires specialized knowledge and skill, consult your dealer. Rust and water scale will accumulate in the cooling system through many hours of operation. This lowers the engine cooling effect. And for the engine oil cooler (3CD1T), they quickly deteriorate the engine oil.

Cooling system parts: radiator, cooling water pump, thermostat, cylinder block, cylinder head, oil cooler (3CD1T).

(2) Checking and replacing fuel hoses and cooling water hoses

As this maintenance requires specialized knowledge and skill, consult your dealer.

Regularly check the rubber hoses of the fuel system and cooling water system. If cracked or degraded, replace them with new one. Replace the rubber hoses at least every 2 years.

(3) Lapping the intake and exhaust valves

As this maintenance requires specialized knowledge and skill, consult your dealer. The adjustment is necessary to maintain proper contact of the valves and seats.

(4) Checking and adjusting the fuel injection timing

As this maintenance requires specialized knowledge and skill, consult your dealer.

5.3.7 Checking and adjusting the EPA emission related parts

The inspection and servicing require specialized knowledge and techniques. Consult your dealer or Isuzu distributor.

EPA allows to apply maintenance schedule for emission related parts as follows.

—	Check Fuel Valve Nozzle and clean	Adjust, cleaning and repair of Fuel injection Pump and Fuel Valve Nozzle
$kW \leq 130$	1500 hours of use and at 1500-hour intervals thereafter	3000 hours of use and at 3000-hour intervals thereafter

6. TROUBLESHOOTING

In case of an abnormality, stop the engine immediately and locate a problem by referring to the following table.

SYMPTOM	PROBABLE CAUSE	ACTION	Ref. Section
Alarm lamps lighting during operation	IMPORTANT: When a alarm lamp lights, immediately stop the engine and check and remove the cause.		
• Engine oil pressure alarm lamp	Insufficient level of engine oil. Clogged engine oil filter	Replenish engine oil. Replace the filter element.	3.3 5.3.1(1)
• Cooling water Temp. alarm lamp	Low radiator cooling water level Contaminated radiator fins Leak of cooling water V-belt is loose or damaged Contaminated cooling water system Faulty cooling water pump	Replenish cooling water Clean the radiator fins Ask for repair Adjust V-belt or replace Ask for service Ask for repair	4.1(4) 5.3.3(2) — 5.3.1(2) — —
• Charge lamp	V-belt is loose or damage Battery failure Faulty alternator	Adjust V-belt or replace Check electrolyte recharge Ask for repair	5.3.1(2) 5.3.2(3) —
Faulty alarm lamp	IMPORTANT: If a alarm lamp is faulty, do not continue operation. Otherwise, faults will not be noticed, developing a serious accident.		
• Charge lamp, engine oil pressure lamp not coming on when starter switch is turned ON (OFF → ON)	Faulty electrical wiring or faulty lamp	Ask for repair	—

SYMPTOM	PROBABLE CAUSE	ACTION	Ref. Section
• Charge lamp, engine oil pressure lamp not going off when starter switch is turned from START to ON (START → ON)	Faulty alternator or faulty engine oil pressure	Ask for repair	—
Failure to start			
• Starter motor works but engine does not start	No fuel	Replenish fuel, bleed	3.2
	Air in fuel system	Bleed	3.2.2
	Improper fuel	Replace with recommended fuel	3.1.1
	Clogged fuel filter	Replace fuel filter	5.3.4(2)
	Poor fuel injection	Ask for repair	—
• Starter motor does not turn or turns too slowly (engine can be turned manually)	Compressed air leakage from intake / exhaust valves	Ask for repair	—
	In sufficient battery charge	Check electrolyte, recharge	5.3.2(3)
	Faulty cable connection at battery terminals	Clean terminals, retighten	—
• Cannot be turned manually	Faulty starter switch	Ask for repair	—
	Faulty starter motor	Ask for repair	—
Poor exhaust gas color			
• Black smoke	Inner parts seized or damaged	Ask for repair	—
	Overloaded	Reduce load	—
	Clogged air cleaner element	Clean element or replace	5.3.3(4) 5.3.4(1)
	Improper fuel	Replace with recommended fuel	3.1.1
• Cannot be turned manually	Faulty spraying of fuel injection	Ask for repair	—
	Excessive intake / exhaust valve clearance	Ask for repair	—

SYMPTOM	PROBABLE CAUSE	ACTION	Ref. Section
• White smoke	Improper fuel	Replace with recommended fuel	3.1.1
	Faulty spraying of fuel injection	Ask for repair	—
	Fuel injection timing delay	Ask for repair	—
	Engine oil burning	Ask for repair	—

TRUBLESHOOTING INFORMATION

If your engine is not working normally, check it referring to the troubleshooting section.

You can of course consult your dealer.

When asking the service, please give the following information to your dealer:

- Model name and serial number of your engine
- The machine unit type, manufacturers name, model and serial number.
- Operating conditions. Which speed or work has brought a problem.
- How long have you used your engine? (Approximate area worked or hours of operation)
- Situation when a trouble is developed
Engine revolution, color of exhaust gas, fuel in use, engine oil type, engine sound, etc.
- History of troubles
- Any other information when a trouble has occurred.

7. ENGINE SPECIFICATIONS

7.1 General

• Description of model name

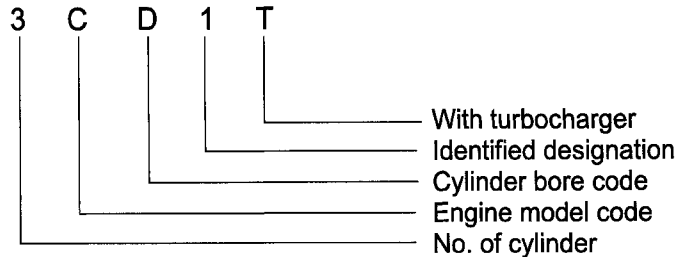

• Engine speed specifications

Notation	Available engine speed min^{-1}	Intended uses
VM	2000 ~ 3000	Agricultural, constructive, industrial machines, etc.
CL	1500 or 1800	4-pole generator sets; irrigation pumps, etc.

VM: Variable, Medium speed

CL: Constant Low speed

• **Engine general specifications**

Type	Vertical inline water cooled 4-cycle diesel engine
Combustion system	Direct injection
Starting system	Electric starting
Cooling system	Radiator
Lubricating system	Forced lubrication with trochoid pump
P.T.O position	Flywheel end
Direction of rotation	Counter-clockwise (viewed from flywheel side)

NOTE:

- 1) *The information described in the principal engine specifications (the next page and after) is for "standard" engine. To obtain the information for the engine installed in your machine unit, please refer to the manual provided by the equipment manufacturer.*
- 2) *Engine rating conditions are as follows (SAE J1349, ISO 3046/1)*
 - *Atmospheric condition: Room temperature 25°C, Atmospheric pressure 100 kPa (750mm Hg), Relative humidity 30%*
 - *Fuel temperature: 25°C (Fuel injection pump inlet)*
 - *With cooling fan, air cleaner, exhaust silencer (Isuzu standard)*
 - *After running-in hours. Output allowable deviation: ±3%*
 - *1PS = 0.7355 kW*

7.2 Principal Engine Specifications

- 3CC1

Engine model	—	3CC1							
Version	—	CL			VM				
Type	—	Vertical inline water cooled diesel engine							
Combustion system	—	Direct injection							
Aspiration	—	Natural							
No. of cylinder	—	3							
Bore × Stroke	mm	82×84							
Displacement	L	1.331							
Continuous rated output / Engine speed	kW/min ⁻¹ (PS)	9.9/1500 (13.5)	12.0/1800 (16.3)	—					
Max. rated output(net) / Engine speed	kW/min ⁻¹ (PS)	11.0/1500 (14.9)	13.2/1800 (17.9)	14.6/2000 (19.9)	16.0/2200 (21.8)	17.5/2400 (23.8)	19.0/2600 (25.8)	20.4/2800 (27.8)	21.9/3000 (29.8)
High idling	min ⁻¹	1600±25	1895±25	2205±25	2420±25	2615±25	2810±25	2995±25	3210±25
Engine mass(dry)** with flywheel housing	kg	138			128				
P.T.O position	—	Flywheel side							
Direction of rotation	—	Counter-clockwise (viewed from flywheel side)							
Cooling system	—	Water cooled (radiator)							
Lubricating system	—	Forced lubrication with trochoid pump							
Starting system	—	Electric starting (Starter motor: DC12V1.2kW, Alternator: DC12V40A) (Recommended battery capacity:12V52Ah (5h rating) for 12V1.2kW S.motor)							
Dimensions (L×W×H)**	mm	553×489×565			528×489×565				
Engine oil capacity (Oil pan)	L	5.5/3.6 (Dipstick upper limit / lower limit)							

7. ENGINE SPECIFICATIONS — 100

Engine model	—	3CC1
Cooling water capacity(engine)	L	1.8
Cooling fan(std.)	—	335mm O/D, 6 blades pusher type

• 3CD1

Engine model	—	3CD1							
Version	—	CL				VM			
Type	—	Vertical inline water cooled diesel engine							
Combustion system	—	Direct injection							
Aspiration	—	Natural							
No. of cylinder	—	3							
Bore × Stroke	mm	84×90							
Displacement	L	1.496							
Continuous rated output / Engine speed	kW/min ⁻¹ (PS)	11.3/1500 (15.3)	13.5/1800 (18.3)	—					
Max. rated output(net) / Engine speed	kW/min ⁻¹ (PS)	12.4/1500 (16.8)	14.8/1800 (20.1)	16.4/2000 (22.3)	18.1/2200 (24.6)	19.7/2400 (26.8)	21.3/2600 (29.0)	23.0/2800 (31.3)	24.6/3000 (33.5)
High idling	min ⁻¹	1600±25	1895±25	2205±25	2420±25	2615±25	2810±25	2995±25	3210±25
Engine mass(dry)** with flywheel housing	kg	161			155				
P.T.O position	—	Flywheel side							
Direction of rotation	—	Counter-clockwise (viewed from flywheel side)							
Cooling system	—	Water cooled (radiator)							
Lubricating system	—	Forced lubrication with trochoid pump							
Starting system	—	Electric starting (Starter motor: DC12V1.2kW, Alternator: DC12V40A) (Recommended battery capacity:12V60Ah (5h rating) for 12V1.2kW S.motor)							
Dimensions (L×W×H)**	mm	589×486×622			564×486×622				

Engine model	—	3CD1
Engine oil capacity (Oil pan)	L	6.7/3.9 (Dipstick upper limit / lower limit)
Cooling water capacity(engine)	L	2.0
Cooling fan(std.)	—	335mm O/D, 6 blades pusher type

** Engine mass and dimensions without radiator

• 3CD1T

Engine model	—	3CD1T								
Version	—	CL				VM				
Type	—	Vertical inline water cooled diesel engine								
Combustion system	—	Direct injection								
Aspiration	—	Turbocharged								
No. of cylinder	—	3								
Bore × Stroke	mm	84×90								
Displacement	L	1.496								
Continuous rated output / Engine speed	kW/min ⁻¹ (PS)	14.0/1500 (19.0)	16.5/1800 (22.5)	—						
Max. rated output(net) / Engine speed	kW/min ⁻¹ (PS)	15.8/1500 (21.5)	18.8/1800 (25.5)	21.0/2000 (28.5)	22.8/2200 (31.0)	25.0/2400 (34.0)	26.8/2600 (36.5)	29.1/2800 (39.5)		
High idling	min ⁻¹	1600±25	1895±25	2205±25	2420±25	2615±25	2810±25	2995±25		
Engine mass(dry)** with flywheel housing	kg	161			155					
P.T.O position	—	Flywheel side								
Direction of rotation	—	Counter-clockwise (viewed from flywheel side)								
Cooling system	—	Water cooled (radiator)								
Lubricating system	—	Forced lubrication with trochoid pump								

Engine model	—	3CD1T			
Starting system	—	Electric starting (Starter motor: DC12V1.2kW, Alternator: DC12V40A) (Recommended battery capacity:12V60Ah (5h rating) for 12V1.2kW S.motor)			
Dimensions (L×W×H)**	mm	589×486×622	564×486×622		
Engine oil capacity (Oil pan)	L	6.7/3.9 (Dipstick upper limit / lower limit)			
Cooling water capacity(engine)	L	2.0			
Cooling fan(std.)	—	350mm O/D, 6 blades pusher type			

• 3CE1

Engine model	—	3CE1							
Version	—	CL		VM					
Type	—	Vertical inline water cooled diesel engine							
Combustion system	—	Direct injection							
Aspiration	—	Natural							
No. of cylinder	—	3							
Bore × Stroke	mm	88×90							
Displacement	L	1.642							
Continuous rated output / Engine speed	kW/min ⁻¹ (PS)	12.3/1500 (16.7)	14.8/1800 (20.1)	—					
Max. rated output(net) / Engine speed	kW/min ⁻¹ (PS)	13.5/1500 (18.4)	16.3/1800 (22.1)	18.0/2000 (24.5)	19.9/2200 (27.0)	21.6/2400 (29.4)	23.5/2600 (31.9)	25.2/2800 (34.2)	27.1/3000 (36.8)
High idling	min ⁻¹	1600±25	1895±25	2205±25	2420±25	2615±25	2810±25	2995±25	3210±25
Engine mass(dry)** with flywheel housing	kg	161		155					
P.T.O position	—	Flywheel side							

7. ENGINE SPECIFICATIONS — 103

Engine model	—	3CE1	
Direction of rotation	—	Counter-clockwise (viewed from flywheel side)	
Cooling system	—	Water cooled (radiator)	
Lubricating system	—	Forced lubrication with trochoid pump	
Starting system	—	Electric starting (Starter motor: DC12V1.2kW, Alternator: DC12V40A) (Recommended battery capacity:12V60Ah (5h rating) for 12V1.2kW S.motor)	
Dimensions (L×W×H)**	mm	589×486×622	564×486×622
Engine oil capacity (Oil pan)	L	6.7/3.9 (Dipstick upper limit / lower limit)	
Cooling water capacity(engine)	L	2.0	
Cooling fan(std.)	—	335mm O/D, 6 blades pusher type	

** Engine mass and dimensions without radiator

All information, illustrations and specifications contained in this manual are based on the latest product information available at the time of publication.
The right is reserved to make changes at any time without notice.

INSTRUCTION MANUAL (INDUSTRIAL)

3CC1, 3CD1, 3CD1T, 3CE1

IDE-6143

Issued by

ISUZU MOTORS LIMITED
POWERTRAIN SERVICE TEAM
OFF-HIGHWAY POWERTRAIN DEPT.
3-1, Kamigo, 4-chome, Ebina, Kanagawa-ken, 243-0434, Japan
TEL 046-234-6057

ISUZU

IDE-6143